

---

TECHNICAL MANUAL

UNIT AND DIRECT SUPPORT MAINTENANCE  
REPAIR PARTS AND SPECIAL TOOLS LIST

FOR

COMPLEXING KIT, PASSAGEWAYS, TYPE II, CLASS A  
SAND, STYLE 1, P/N 5-4-6730-1 (81337)  
SAND, STYLE 2, P/N 5-4-6730-3 (81337)  
GREEN, STYLE 1, P/N 5-4-6730-2 (81337)  
GREEN, STYLE 2, P/N 5-4-6730-4 (81337)  
COMPLEXING KIT, PASSAGEWAYS, TYPE II, CLASS B  
SAND, STYLE 1, P/N 5-4-6731-1 (81337)  
SAND, STYLE 2, P/N 5-4-6731-3 (81337)  
GREEN, STYLE 1, P/N 5-4-6731-2 (81337)  
GREEN, STYLE 2, P/N 5-4-6731-4 (81337)  
COMPLEXING KIT, PASSAGEWAYS, TYPE I  
SAND, STYLE 1, P/N 5-4-6732-1 (81337)  
SAND, STYLE 2, P/N 5-4-6732-3 (81337)  
SAND, STYLE 3, P/N 5-4-6732-5 (81337)  
GREEN, STYLE 1, P/N 5-4-6732-2 (81337)  
GREEN, STYLE 2, P/N 5-4-6732-4 (81337)  
GREEN, STYLE 3, P/N 5-4-6732-6 (81337)

DISTRIBUTION STATEMENT A: Approved for public release; distribution is unlimited.

\* This manual supersedes TM 10-5411-203-23P, dated 10 July 1990.

TECHNICAL MANUAL  
NO. 10-5411-203-23P

HEADQUARTERS,  
DEPARTMENTS OF THE ARMY,  
WASHINGTON D.C., 31 August 1994

**TECHNICAL MANUAL**

**Unit and Direct Support Maintenance  
Repair Parts and Special Tools List**

for

- COMPLEXING KIT, PASSAGEWAYS, TYPE II, CLASS A**
- SAND, STYLE 1, P/N 5-4-6730-1 (8133-
- SAND, STYLE 2, P/N 5-4-6730-3 (81337)
- GREEN, STYLE 1, P/N 5-6730-2 (81337)
- GREEN, STYLE 2, P/N 5-4-6730-4 (81337)
- COMPLEXING KIT, PASSAGEWAYS, TYPE II, CLASS B**
- SAND, STYLE 1, P/N 5-4-6731-1 (81337)
- SAND, STYLE 2, P/N 5-4-6731-3 (81337)
- GREEN, STYLE 1, P/N 5-4-6731-2 (81337)
- GREEN, STYLE 2, P/N 5-4-6731-4 (81337)
- COMPLEXING KIT, PASSAGEWAYS, TYPE I**
- SAND, STYLE 1, P/N 6-4-6732-1 (81337)
- SAND, STYLE 2, P/N 5-4-6732-3 (81337)
- SAND, STYLE 3, P/N 5-4-6732-5 (81337)
- GREEN, STYLE 1, P/N 5-4-6732-2 (81337)
- GREEN, STYLE 2, P/N 5-4-6732-4 (81337)
- GREEN, STYLE 3, P/N 54-6732-6 (81337)

Current as of 15 July 1994

**REPORTING ERRORS AND RECOMMENDING IMPROVEMENTS**

You can help improve this manual. If you find any mistakes or if you know of a way to improve the procedures, please let us know. Mail your letter, DA Form 2028 (Recommended Changes to Publications and Blank Forms), or DA Form 2028-2 located in the back of this manual directly to: Commander US Army Aviation and Troop Command, ATTN: AMSAT-I-MP, 4300 Goodfellow Blvd., St. Louis MO 63120-1798. A reply will be furnished directly to you.

DISTRIBUTION STATEMENT A: Approved for public release; distribution is unlimited.

**TABLE OF CONTENTS**

		PAGE	ILLUS/ FIGURE
Section I.	INTRODUCTION .....	1	
Section II.	REPAIR PARTS LIST .....	1-1	
Group 00	Complexing Kit Passageways		
	Complexing Kit Passageways .....	1-1	1
Group 01	Complexing Kit Passageways, Type II		
	Passageways, ISO to Temper .....	2-1	2

\*This manual supersedes TM 10-5411 -203-23P dated 10 July 1990.

	PAGE	ILLUS/ FIGURE
Group 01	Complexing Kit Passageways, Type II (ISO to Temper) (Continued)	
	Ramp Assembly (ISO to Temper) .....	3-1            3
	Stairway Assembly (ISO to Temper) .....	4-1            4
	Exterior Frame Assembly (Temper) .....	5-1            5
	Frame Assented (ISO) .....	6-1            6
	Connector Assembly (ISO to Temper) .....	7-1            7
	Bump through Doom (ISO to Temper) .....	8-1            8
Group 02	Complexing-Kit Passageways, Type I (ISO to ISO)	
	Passageways (ISO to ISO) .....	9-1            9
	Ramp Assembly (ISO to ISO) .....	10-1           10
	Frame Assembly (ISO).....	11-1           11
	Connector - (ISO to ISO) .....	12-1           12
	Bump through Doors (ISO to ISO) .....	13-1           13
Section III.	SPECIAL TOOLS LIST (Not Applicable)	
Section IV.	CROSS REFERENCE INDEXES	
	National Stock Number Index .....	I-1
	Part Number index .....	I-2
	Figure and Item Number Index .....	I-8

**UNIT, DIRECT SUPPORT AND GENERAL SUPPORT  
MAINTENANCE REPAIR PARTS AND SPECIAL TOOLS LIST**

SECTION I. INTRODUCTION

**1. SCOPE.** This RPSTL lists and authorizes spares and repair parts; special tools; special test, measurement, and diagnostic equipment (TMDE); and other special support equipment required for performance of unit, direct support and general support maintenance of the Complexing Kit Passageways. It authorizes the requisitioning, issue, and disposition of spares, repair parts and special tools as indicated by the source, maintenance and recoverability (SMR) codes.

**2. GENERAL.** In addition to this section, Introduction, this Repair Parts and Special Tools List is divided into the following sections:

a. Section II. Repair Parts List. A list of spares and repair parts authorized by this RPSTL for use in the performance of maintenance. This list also includes parts which must be removed for replacement of the authorized parts. Parts lists are composed of functional groups in ascending alphanumeric sequence, with the parts in each group listed in ascending figure and item number sequence. Bulk materials are listed in item name sequence. Repair parts kits are listed separately in functional groups in Section II. Repair parts for repairable special tools are also listed in this section. Items listed are shown in the associated illustration(s)/figure(s).

b. Section III. Special Tools List. A list of special tools, special TMDE, and other special support equipment authorized by this RPSTL (as indicated by Basis of Issue (BOI) information in DESCRIPTION AND USABLE ON CODE column) for the performance of maintenance.

c. Section IV. Cross-Reference Index. A list, in National Item Identification Number (NIIN) sequence, of all national stock numbered items appearing in the listing, followed by a list in alphanumeric sequence of all part numbers appearing in the listings. National stock numbers and part numbers are cross referenced to each illustration figure and item number appearance. The figure and item number index lists figure and item numbers in alphanumeric sequence and cross references NSN, CAGEC and part number.

**3. EXPLANATION OF COLUMNS (SECTIONS II AND III).**

a. ITEM NO. (Column (1)). Indicates the number used to identify items called out in the illustration.

b. SMR Code (Column (2)). The Source, Maintenance, and Recoverability (SMR) code is a 5-position code containing supply/requisitioning information, maintenance category authorization criteria, and disposition instruction, as shown in the following breakout:

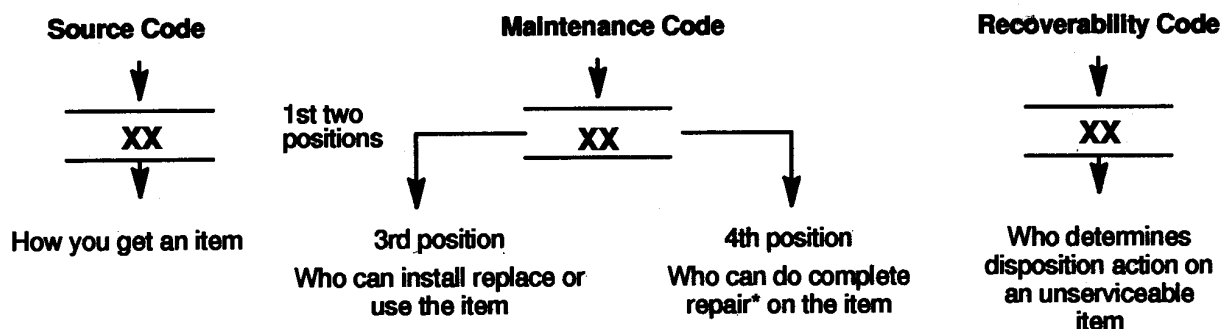

\* Complete Rear: Maintenance capacity, capability, and authority to perform all corrective maintenance tasks of the "Repair" function in a use/user environment in order to restore serviceability to a failed item.

(1) Source Code. The source code tells you how you get an item needed for maintenance, repair, or overhaul of an end item/equipment. Explanations of source codes follow.

Code	Explanation
PA PB PC** PD PE PF PG	<p>Stocked items; use the applicable NSN to request/requisition items with these source codes. They are authorized to the category indicated by the code entered in the 3rd position of the SMR code.</p> <p>**NOTE : Items coded PC are subject to deterioration.</p>
KD KF KB	<p>Items with these codes are not to be requested/requisitioned individually. They are part of a kit which is authorized to the maintenance category indicated in the 3rd position of the SMR code. The complete kit must be requisitioned and applied.</p>
MO (Made at org AVUM level) MF (Made at DS/AVUM level) MH (Made at GS level) ML (Made at Specialized Repair Activity (SRA)) MD (Made at Depot)	<p>Items with these codes are not to be requested/requisitioned individually. They must be made from bulk material which is identified by the part number in the DESCRIPTION and USABLE ON CODE (UOC) column and listed in the Bulk Material group of the repair parts list in the RPSTL. If the item is authorized to you by the 3rd position code of the SMR code, but the source code indicates it is made at a higher level, order the item from the higher level of maintenance.</p>
AO (Assembled by org AVUM Level) AF (Assembled by DS/AVUM Level) AH (Assembled by GS Category) AL (Assembled by SRA) AD (Assembled by Depot)	<p>Items with these codes are not to be requested/requisitioned individually. The parts that make up the assembled item must be requisitioned or fabricated and assembled at the level of maintenance indicated by the source code. If the 3rd position code of the SMR code, authorizes you to replace the item, but the source code indicates the items are assembled at a higher level, order the item from the higher level of maintenance.</p>
Code	Explanation
XA - -	Do not requisition an "XA"-coded item. Order its next higher assembly. (Also, refer to the NOTE below.)
XB - -	If an "XB" item is not available from salvage, order it using the CAGE Code and part number given.
XC - -	Installation drawing, diagram, instruction sheet, field service drawing, that is identified by manufacturer's part number.
XD - -	Item is not stocked. Order an "XD"-coded item through normal supply channels using the CAGE Code and part number given, if no NSN is available.

**NOTE**

Cannibalization or controlled exchange, when authorized, may be used as a source of supply for items with the above source codes, except for those source coded "XA" or those aircraft support items restricted by requirements of AR 750-1

(2) Maintenance Code. Maintenance codes tell you the level(s) of maintenance authorized to USE and REPAIR support items. The maintenance codes are entered in the third and fourth positions of the SMR code as follows:

(a) The maintenance code entered in the third position tells you the lowest maintenance level authorized to remove, replace, and use an item. The maintenance code entered in the third position will indicate authorization to the following levels of maintenance.

**Maintenance**

**Code**

**Application/Explanation**

- C - Crew or operator maintenance done within unit/AVUM maintenance.
- O - Unit level VAVUM maintenance can remove, replace, and use the item.
- F - Direct support/AVIM maintenance can remove, replace, and use the item.
- H - General support maintenance can remove, replace, and use the item.
- L - Specialized repair activity can remove, replace, and use the item.
- D - Depot can remove, replace, and use the item.

(b) The maintenance code entered in the fourth position tells whether or not the item is to be repaired and identifies the lowest maintenance level with the capability to do complete repair (i.e., perform all authorized repair functions). This position will contain one of the following maintenance codes.

**NOTE**

Some limited repair may be done on an item at a lower level of maintenance, if authorized by the Maintenance Allocation Chart (MAC) and SMR codes.

**Maintenance**

**Code**

**Application/Explanation**

- O - Unit VAVUM is the lowest level that can do complete repair of the item.
- F - Direct support VAVIM is the lowest level that can do complete repair of the item.
- H - General Support is the lowest level that can do complete repair of the item.
- L - Specialized repair activity is the lowest level that can do complete repair of the item.
- D - Depot is the lowest level that can do complete repair of the item.
- Z - Nonreparable. No repair is authorized.
- B - No repair is authorized. No parts or special tools are authorized for the maintenance of a "B" coded item. However, the item may be reconditioned by adjusting, lubricating, etc., at the user level.

(3) Recoverability. Recoverability codes are assigned to items to indicate the disposition action on unserviceable items. The recoverability code is entered in the fifth position of the SMR Code as follows:

**Recoverability  
Codes**

**Application/Explanation**

- Z - Nonreparable item. When unserviceable, condemn and dispose of the item at the level of maintenance shown in 3rd position of SMR Code.
- O - Reparable item. When not economically reparable, condemn and dispose of the item at unit or AVUM level.
- F - Reparable item. When uneconomically reparable, condemn and dispose of the item at the direct support or AVIM level.
- H - Reparable item. When uneconomically reparable, condemn and dispose of the item at the general support level.
- D - Reparable item. When beyond lower level repair capability, return to depot. Condemnation and disposal of item not authorized below depot level.
- L - Reparable item. Condemnation and disposal not authorized below specialized repair activity (SRA).
- A - Item requires special handling or condemnation procedures because of specific reasons (e.g., precious metal content, high dollar value, critical material, or hazardous material). Refer to appropriate manuals/directives for specific instructions.

c. CAGEC (Column (3)). The Commercial and Government Entity Code (CAGEC) is a 5-digit numeric code which is used to identify the manufacturer, distributor, or Government agency/activity that supplies the item.

d. PART NUMBER (Column (4)). Indicates the primary number used by the manufacturer, (individual, company, firm, corporation, or Government activity), which controls the design and characteristics of the item by means of its engineering drawings, specifications, standards, and inspection requirements to identify an item or range of items.

**NOTE**

When you use an NSN to requisition an item, the item you receive may have a different part number from the number listed.

e. DESCRIPTION AND USABLE ON CODE (UOC) (Column (5)). This column includes the following information:

- (1) The Federal item name and, when required, a minimum description to identify the item.
- (2) Part numbers of bulk materials are referenced in this column in the line entry for the item to be manufactured/fabricated.
- (3) The statement "END OF FIGURE" appears just below the last item description in Column (5) for a given figure in both Section II and Section III.

f. QTY (Column (6)). The QTY (quantity per figure) column indicates the quantity of the item used in the breakout shown on the illustration/figure, which is prepared for a functional group, subfunctional group, or an assembly. A "V" appearing in this column instead of a quantity indicates that the quantity is variable and may vary from application to application.

**4. EXPLANATION OF INDEX FORMAT AND COLUMNS (SECTION IV).**

a. NATIONAL STOCK NUMBER (NSN) INDEX.

(1) STOCK NUMBER Column. This column lists the NSN in national item identification number (NIIN) sequence. The NIIN consists of the last nine digits of the NSN, i.e.

NSN
5305-01-574-1467
NIIN

When using this column to locate an item, ignore the first four digits of the NSN. Use the complete NSN (1 3 digits) when requisitioning items by stock number.

(2) FIG. Column. This column lists the number of the figure where the item is identified/located. The figures are in numerical order in Section II and Section III.

(3) ITEM Column. The item number identifies the item associated with the figure listed in the adjacent FIG. column. This item is also identified by the NSN listed on the same line.

b. PART NUMBER INDEX. Part numbers in this index are listed in ascending alphanumeric sequence (i. e., vertical arrangement of letter and number combinations which place the first letter or digit of each group in order A through Z, followed by the numbers 0 through 9, and each following letter or digit in like order).

(1) CAGEC Column. The Commercial and Government Entity Code (CAGEC) is a 5-digit numeric code used to identify the manufacturer, distributor, or Government agency/activity that supplies the item.

(2) PART NUMBER Column. Indicates the primary number used by the manufacturer (individual, firm, corporation, or Government activity), which controls the design and characteristics of the item by means of its engineering drawings, specifications, standards, and inspection requirements to identify an item or range of items.

(3) STOCK NUMBER Column. This column lists the NSN for the associated part number and manufacturer identified in the PART NUMBER and CAGEC columns to the left.

(4) FIG. Column. This column lists the number of the figure where the item is identified/located in Section II and Section II.

(5) ITEM Column. The item number is that number assigned to the item as it appears in the figure referenced in the adjacent figure number column.

c. FIGURE AND ITEM NUMBER INDEX.

(1) FIG. Column. This column lists the number of the figure where the item is identified/located in Section II and Section III.

(2) ITEM Column. The item number is that number assigned to the item as it appears in the figure referenced in the adjacent figure number column.

(3) STOCK NUMBER Column. This column lists the NSN for the item.

(4) CAGEC Column. The Commercial and Government Entity Code (CAGEC) is a 5-digit numeric code used to identify the manufacturer, distributor, or Government agency/activity that supplies the item.

(5) PART NUMBER Column. Indicates the primary number used by the manufacturer (individual, firm, corporation, or Government activity), which controls the design and characteristics of the item by means of its engineering drawings, specifications, standards, and inspection requirements to identify an item or range of items.



**5. SPECIAL INFORMATION.**

a. USABLE ON CODE. The usable on code appears in the lower left corner of the Description column heading. Usable on codes are shown as "UOC:.." in the Description Column (justified left) on the last line of the applicable item description/nomenclature. Uncoded items are applicable to all models. Identification of the usable on codes used in this RPSTL are:

<u>Code</u>	<u>Used On</u>
FDA	ISO to Temper, with ramp, green
FDB	ISO to Temper, with stairs, green
FDC	ISO to ISO, green
FDD	ISO to Temper, with ramp, sand
FDE	ISO to Temper, with stairs, sand
FDF	ISO to ISO, sand
FDG	ISO to Temper, with ramp and bump thru doors, green
FDH	ISO to Temper, with stairs and bump thru doors, green
FDJ	ISO to ISO, with one set of bump thru doors, green
FDK	ISO to Temper, with ramp and bump thru doors, sand
FDL	ISO to Temper, with stairs and bump thru doors, sand
FDM	ISO to ISO, with one set of bump thru doors, sand
FDN	ISO to ISO, with two sets of bump thru doors, green
FDP	ISO to ISO, with two sets of bump thru doors, sand

b. FABRICATION INSTRUCTIONS. Bulk materials required to manufacture items are listed in the Bulk Material Functional Group of this RPSTL. Part numbers for bulk materials are also referenced in the description column of the line item entry for the item to be manufactured/fabricated. Detailed fabrication instructions for items source coded to be manufactured or fabricated are found in TM 10-5411-203 23P.

c. INDEX NUMBERS. Items which have the word BULK in the figure column will have an index number shown in the item number column. This index number is a cross-reference between the National Stock Number/Part Number Index and the bulk material list in Section II.

d. ASSOCIATED PUBLICATIONS. The publications listed below pertain to the Air Conditioner and its components.

<u>Publication</u>	<u>Short Title</u>
TM 10-5411-203 23P	Operator, Unit, Direct Support Support Maintenance Manual.

**6. HOW TO LOCATE REPAIR PARTS.**

a. When National Stock Numbers or Part Numbers are NOT Known.

(1) First. Using the table of contents, determine the assembly or subassembly group to which the item belongs. This is necessary since figures are prepared for assembly groups and subassembly groups, and listings are divided into the same groups.

(2) Second. Find the figure covering the assembly group or subassembly group to which the item belongs.

(3) Third. Identify the item on the figure and use the Figure and Item Number Index to find the NSN.

b. When National Stock Number or Part Number is Known.

(1) First. Using the of National Stock Number and Part Number Indexes find the pertinent National Stock Number or Part Number. The NSN index is in National Item Identification Number (NIIN) sequence (see paragraph 4.a.). The part numbers in the Part Number index are listed in ascending alphanumeric sequence (see paragraph 4.b.). Both indexes cross-reference you to the illustration/figure and item number of the item you are looking for.

(2) Second. Turn to the figure and item number, verify that the item is the one you are looking for, then locate the item number in the repair parts list for the figure.

**7. ABBREVIATIONS.** Abbreviations used in this manual are listed in MIL-STD-12.

**7/(8 blank)**

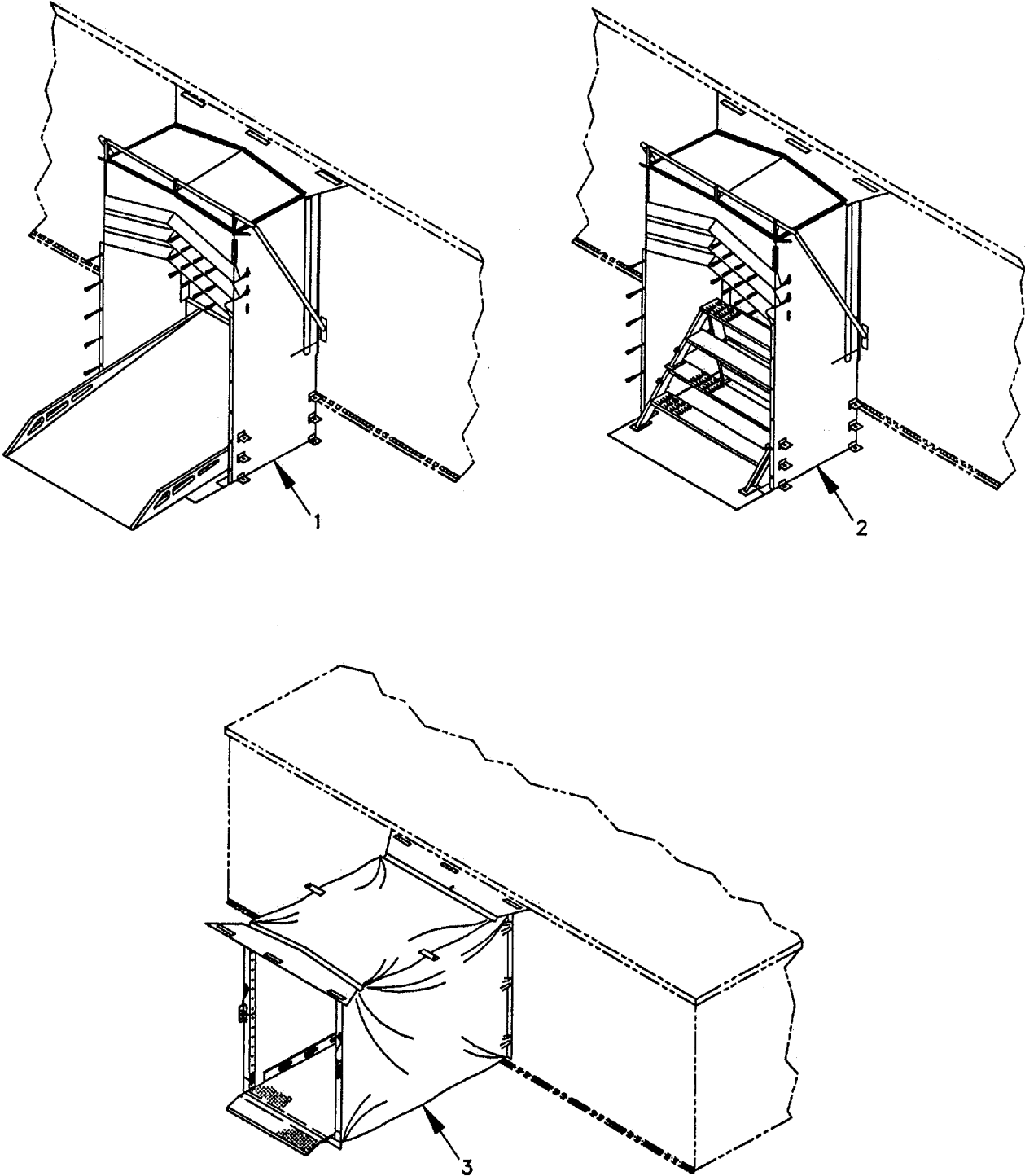

Figure 1. COMPLEXING KIT PASSAGEWAYS

## SECTION II

TM 10-5411-203-23P

(1) ITEM NO	(2) SMR CODE	(3) CAGEC	(4) PART NUMBER	(5) DESCRIPTION AND USABLE ON CODES (UOC)	(6) QTY
				<b>GROUP 00</b>	
				<b>FIG. 1</b>	
				<b>COMPLEXING KIT PASSAGEWAYS</b>	
				<b>COMPLEXING KIT PASSAGEWAYS</b>	
1	PDOOF	81337	5-4-6730-1	PASSAGEWAY ISO TO TEMPER, TYPE II, ..... CLASS A, STYLE 1, TAN UOC:FDD	1
1	PDOOF	81337	5-4-6730-2	PASSAGEWAY ISO TO TEMPER, TYPE II, ..... CLASS A, STYLE 1, GREEN UOC:FDA	1
1	PDOOF	81337	5-4-6730-3	PASSAGEWAY TSO TO TEMPER, TYPE II, ..... CLASS A, STYLE 2, TAN UOC:FDK	1
1	PDOOF	81337	5-4-6730-4	PASSAGEWAY ISO TO TEMPER, TYPE II, ..... CLASS A, STYLE 2, GREEN UOC:FDG	1
2	PDOOF	81337	5-4-6731-1	PASSAGEWAY ISO TO TEMPER, TYPE II, ..... CLASS B, STYLE 1, TAN UOC:FDE	1
2	PDOOF	81337	5-4-6731-2	PASSAGEWAY ISO TO TEMPER, TYPE II, ..... CLASS B, STYLE 1, GREEN UOC:FDB	1
2	PDOOF	81337	5-4-6731-3	PASSAGEWAY ISO TO TEMPER, TYPE II, ..... CLASS B 9 STYLE 2, TAN UOC:FDL	1
2	PDOOF	81337	5-4-6731-4	PASSAGEWAY ISO TO TEMPER, TYPE II, ..... CLASS B, STYLE 2, GREEN UOC:FDH	1
3	PDOOF	81337	5-4-6732-1	PASSAGEWAY ISO TO ISO, TYPE I, STYLE ..... 1, TAN UOC:FDI	1
3	PDOOF	81337	5-4-6732-2	PASSAGEWAY ISO TO ISO, TYPE I, STYLE ..... 1, GREEN UOC:FDC	1
3	PDOOF	81337	5-4-6732-3	PASSAGEWAY ISO TO ISO, TYPE I, STYLE ..... 2, TAN UOC:FDM	1
3	PDOOF	81337	5-4-6732-4	PASSAGEWAY ISO TO ISO, TYPE I, STYLE ..... 2, GREEN UOC:FDJ	1
3	PDOOF	81337	5-4-6732-5	PASSAGEWAY ISO TO ISO, TYPE I, STYLE ..... 3, TAN UOC:FDP	1
3	PDOOF	81337	5-4-6732-6	PASSAGEWAY ISO TO ISO, TYPE I, STYLE ..... 3, GREEN UOC:FDN	1
				END OF FIGURE	

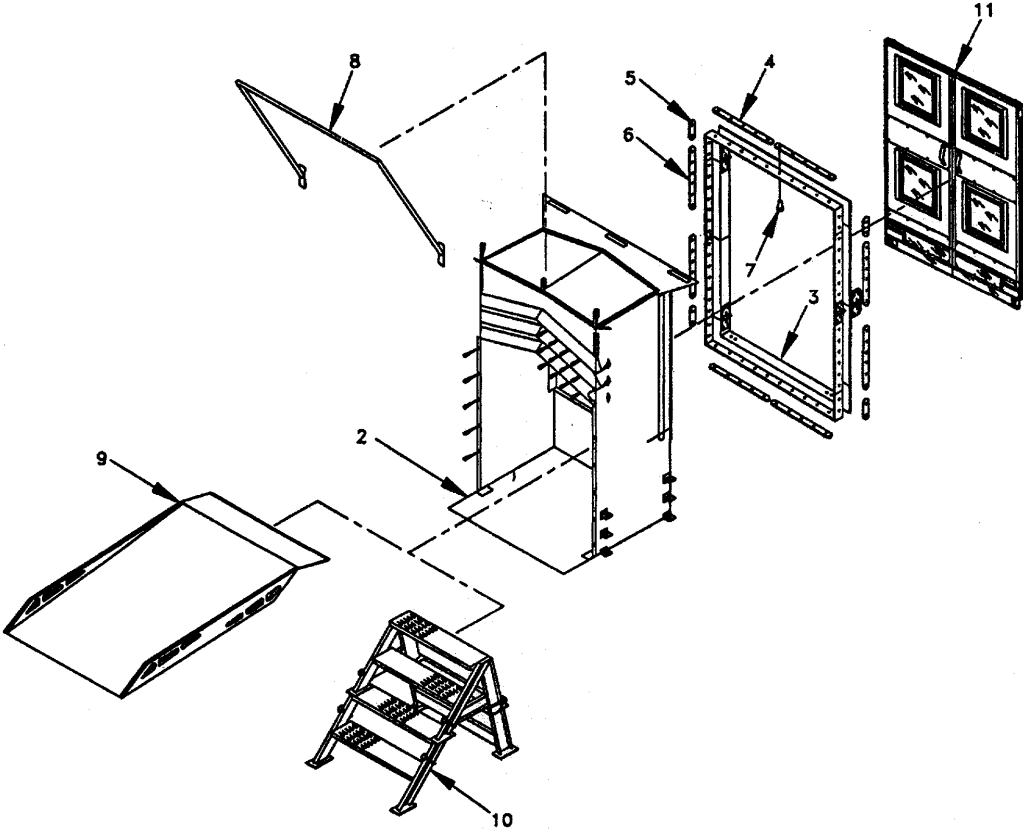
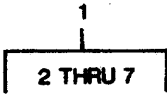

FIGURE 2 . PASSAGEWAYS - ISO TO TEMPER (TYPE II)

SECTION II

TM 10-5411-203-23P

(1) ITEM NO	(2) SMR CODE	(3) CAGEC	(4) PART NUMBER	(5) DESCRIPTION AND USABLE ON CODES (UOC)	(6) QTY
				<b>GROUP 01</b>	
				<b>FIG. 2</b>	
				<b>COMPLEXING KIT PASSAGEWAYS - TYPE II PASSAGEWAYS - ISO TO TEMPER (TYPE II)</b>	
1	XDOFF	81337	5-4-8258-1	FRAME-CONNECTOR ISO TO TEMPER, SAND. ... UOC:FDD, FDE, FDK, FDL	1
1	XDOFF	81337	5-4-8258-2	FRAME-CONNECTOR ISO TO TEMPER, GREEN.. UOC:FDA, FDB, FDG, FDH	1
2	XBOFF	81337	5-4-4181-1	CONNECTOR ASSY ISO TO TEMPER, SAND..... UOC:FDD, FDE, FDK, FDL	1
2	XDOFF	81337	5-4-4181-2	CONNECTOR ASSY ISO TO TEMPER, ..... GREEN UOC:FDA, FDB, FDG, FDH	1
3	XBOFF	81337	5-4-4204-1	FRAME ASSY SAND .....	1
3	XBOFF	81337	5-4-4204-2	FRAME ASSY GREEN.....	1
4	XBOZZ	81337	5-4-6662-1	UOC:FDA, FDB, FDG, FDH RETAINER STRIP TOP AND BOTTOM, ..... FRAME-CONNECTOR, SAND UOC:FDD, FDE, FDK, FDL	4
4	XBOZZ	81337	5-4-6662-2	RETAINER STRIP TOP AND BOTTOM, ..... FRAME-CONNECTOR, GREEN UOC:FDA, FDG, FDH, FDL	4
5	XBOZZ	81337	5-4-4213-1	RETAINER STRIP CQRNER, FRAME- ..... CONNECTOR, SAND UOC:FDD, FDE, FDK, FDL	4
5	XBOZZ	81337	5-4-4213-2	RETAINER STRIP CORNER , FRAME- ..... CONNECTOR, GREEN UOC:FDA, FDB,FDG, FDH	4
6	XBOZZ	81337	5-4-6663-1	RETAINER STRIP SIDE, FRAME- ..... CONNECTOR, SAND UOC : FDD, FDE, FDK, FDL	4
6	XBOZZ	81337	5-4-6663-2	RETAINER STRIP SIDE, FRAME- ..... CONNECTOR, GREEN UOC:FDA, FDB, FDG, FDH	4
7	XDOZZ	81349	M24243/6-A606F/G G	RIVET, BLIND NON-STRUCTURAL, FILLED..... CORE, CLOSED END, 3/16 IN. DIA, 3/8 IN. GR UOC:FDA, FDB, FDD, FDE, FDG, FDH.FDK, FDL	52
8	XDOOO	81337	5-4-4196-1	EXTERIOR FRAME ASSY SAND.....	1
8	XDOFF	81337	5-4-4196-2	EXTERIOR FRAME ASSY GREEN.....	1
9	XDOOO	81337	5-4-6733-1	UOC:FDA, FDB, FDG, FDH RAMP, ISO-TEMPER SAND .....	1
9	XDOFF	81337	5-4-6733-2	UOC:FDD, FDK RAMP, ISO-TEMPER GREEN .....	1
10	XBOFF	81337	5-4-4029-1	UOC:FDA, FDG STAIRWAY, ADJUSTABLE SAND .....	1
10	XBOFF	81337	5-4-4029-2	UOC:FDE, FDL STAIRWAY, ADJUSTABLE GREEN .....	1
				UOC:FDB, FDH	

**SECTION II**

**TM 10-5411-203-23P**

(1) ITEM NO	(2) SMR CODE	(3) CAGEC	(4) PART NUMBER	(5) DESCRIPTION AND USABLE ON CODES (UOC)	(6) QTY
11	XBOFF	81337	5-4-7532-1	DOORS, DOUBLE, TY III BUMP THROUGH, ..... GREEN, INCLUDES CARRYING CASE UOC:FDK, FDL	1
11	PDOFZ	81337	5-4-7532-2	DOOR, TENT BUMP THROUGH, SAND, ..... INCLUDES CARRYING CASE UOC:FDG, FDH END OF FIGURE	1

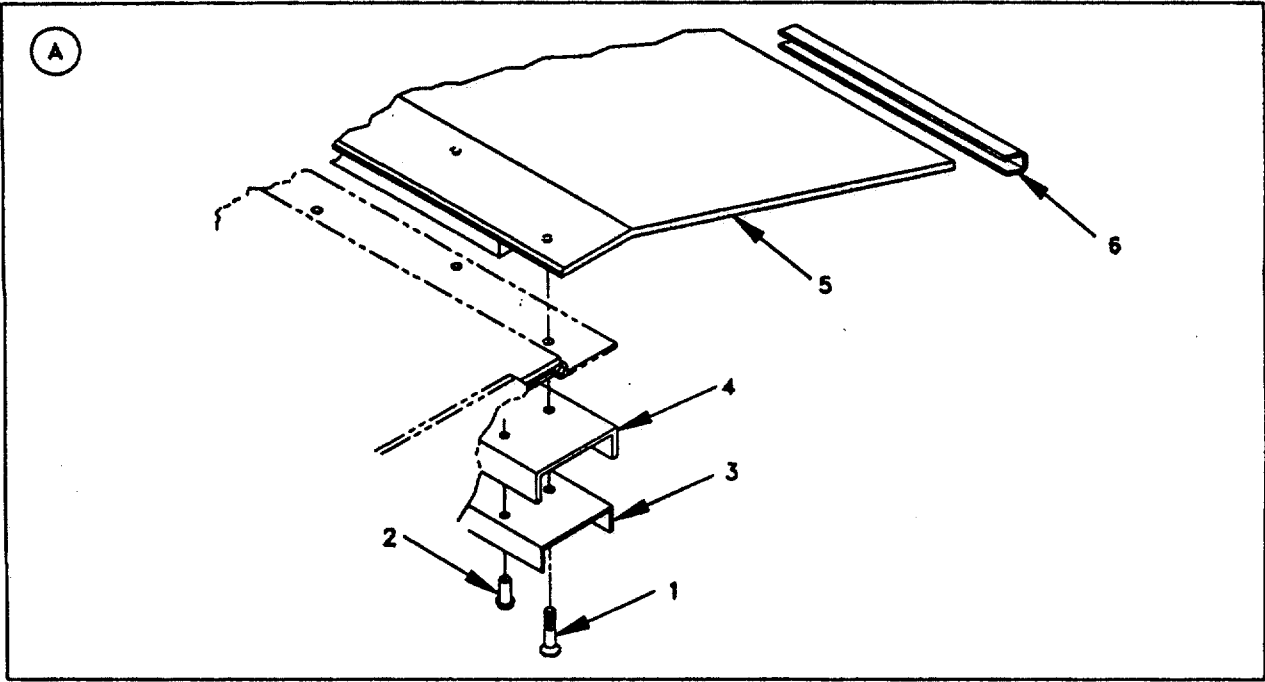
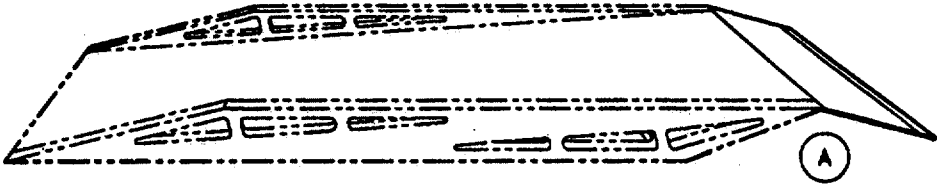

FIGURE 3 . RAMP ASSEMBLY (ISO TO TEMPER)



SECTION II

TM 10-5411-203-23P

(1) ITEM NO	(2) SMR CODE	(3) CAGEC	(4) PART NUMBER	(5) DESCRIPTION AND USABLE ON CODES (UOC)	(6) QTY
				<b>GROUP 01      COMPLEXING KIT PASSAGEWAYS - TYPE II</b>	
				<b>FIG. 3          RAMP ASSEMBLY (ISO TO TEMPER)</b>	
1	XDOZZ	96906	MS51960-66	SCREW,MACHINE #10-32UNF-2A X .62L..... UOC:FDA,FDD,FDG,FDK	6
2	XDOZZ	96906	MS20426-AD4-7	RIVET,FLAT HEAD..... UOC:FDA,FDD,FDG,FDK	6
3	XDOZZ	81337	5-4-6751-1	LINER .....	1
4	XDOZZ	81337	5-4-6750-1	UOC:FDA,FDD,FDG,FDK THRESHOLD CHANNEL SAND .....	1
4	XDOZZ	81337	5-4-6750-2	UOC:FDD,FDK THRESHOLD CHANNEL GREEN .....	1
5	XDOOO	81337	5-4-6747-1	UOC:FDA,FDG END PLATE ASSY SAND .....	1
5	XDOZZ	81337	5-4-6747-2	UOC:FDD,FDK END PLATE ASSY GREEN .....	1
6	XBOZZ	81337	5-4-6475-1	UOC:FDA,FDG EDGE PROTECTOR .....	1
				UOC:FDA,FDD,FDG,FDK END OF FIGURE	

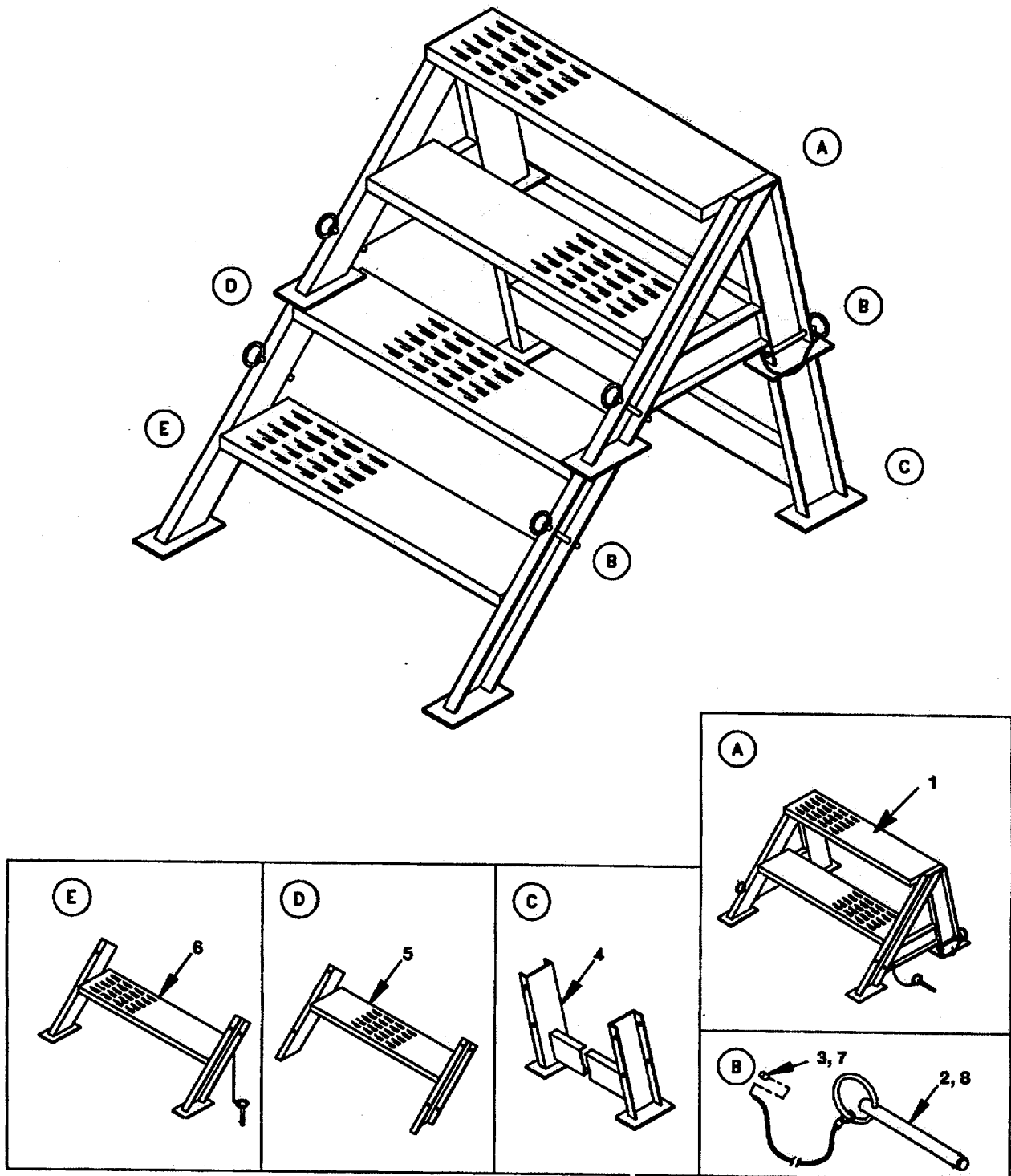

FIGURE 4. STAIRWAY ASSEMBLY (ISO TO TEMPER)

SECTION II

TM 10-5411-203-23P

(1) ITEM NO	(2) SMR CODE	(3) CAGEC	(4) PART NUMBER	(5) DESCRIPTION AND USABLE ON CODES (UOC)	(6) QTY
				<b>GROUP 01      COMPLEXING KIT PASSAGEWAYS</b>	
				<b>- TYPE II</b>	
				<b>FIG. 4      STAIRWAY ASSEMBLY</b>	
				<b>(ISO TO TEMPER)</b>	
1	XBOOO	81337	5-4-4032-1	STAIR & RISER ASSY UPPER,SAND .....	1
				UOC:FDE,FDL	
1	XBOOO	81337	5-4-4032-2	STAIR & RISER ASSY UPPER,GREEN .....	1
				UOC:FDB,FDH	
2	XBOZZ	81337	5-4-4227-1	PIN & LANYARD ASSY.....	4
				UOC:FDB,FDE,FDH,FDL	
3	XBOZZ	96906	MS51844-82	SWAGING SLEEVE,WIRE WIRE ROPE .....	4
				UOC:FDB,FDE,FDH,FDL	
4	XBOZZ	81337	5-4-4228-1	CROSS SUPPORT ASSY REAR,SAND .....	1
				UOC:FDE,FDL	
4	XBOZZ	81337	5-4-4228-2	CROSS SUPPORT ASSY REAR,GREEN .....	1
				UOC:FDB,FDH	
5	XBOZZ	81337	5-4-4031-1	RISER ASSY MIDDLE,SAND .....	1
				UOC:FDE,FDL	
5	XBOZZ	81337	5-4-4031-2	RISER ASSY MIDDLE,GREEN .....	1
				UOC : FDB,FDH	
6	XBOZZ	81337	5-4-4030-1	RISER ASSY LOWER,SAND .....	1
				UOC:FDE,FDL	
6	XBOZZ	81337	5-4-4030-2	RISER ASSY LOWER,GREEN .....	1
				UOC:FDB,FDH	
7	XBOZZ	81337	5-4-4227-1	PIN & LANYARD ASSY .....	2
				UOC:FDB,FDE,FDH,FDL	
8	XBOZZ	96906	MS51844-82	SWAGING SLEEVE WIRE ROPE.....	2
				UOC:FDB,FDE,FDH,FDL	
				END OF FIGURE	

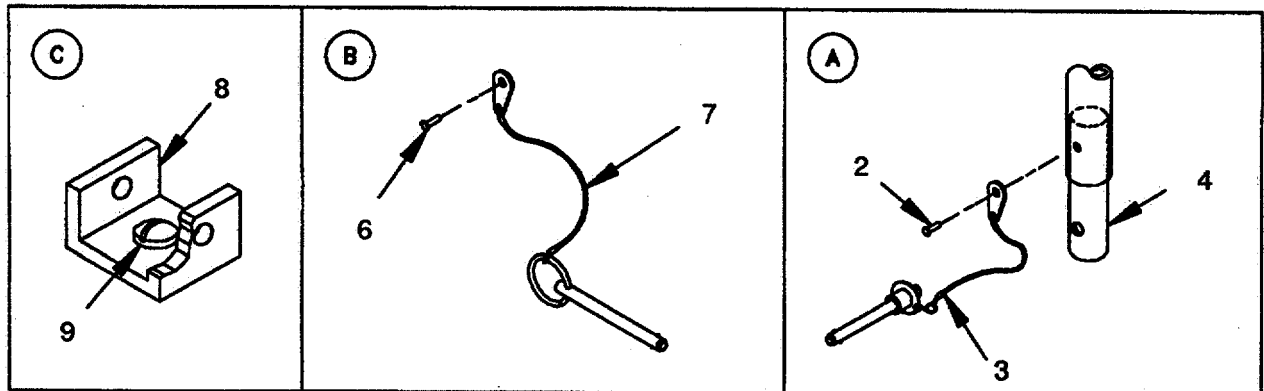
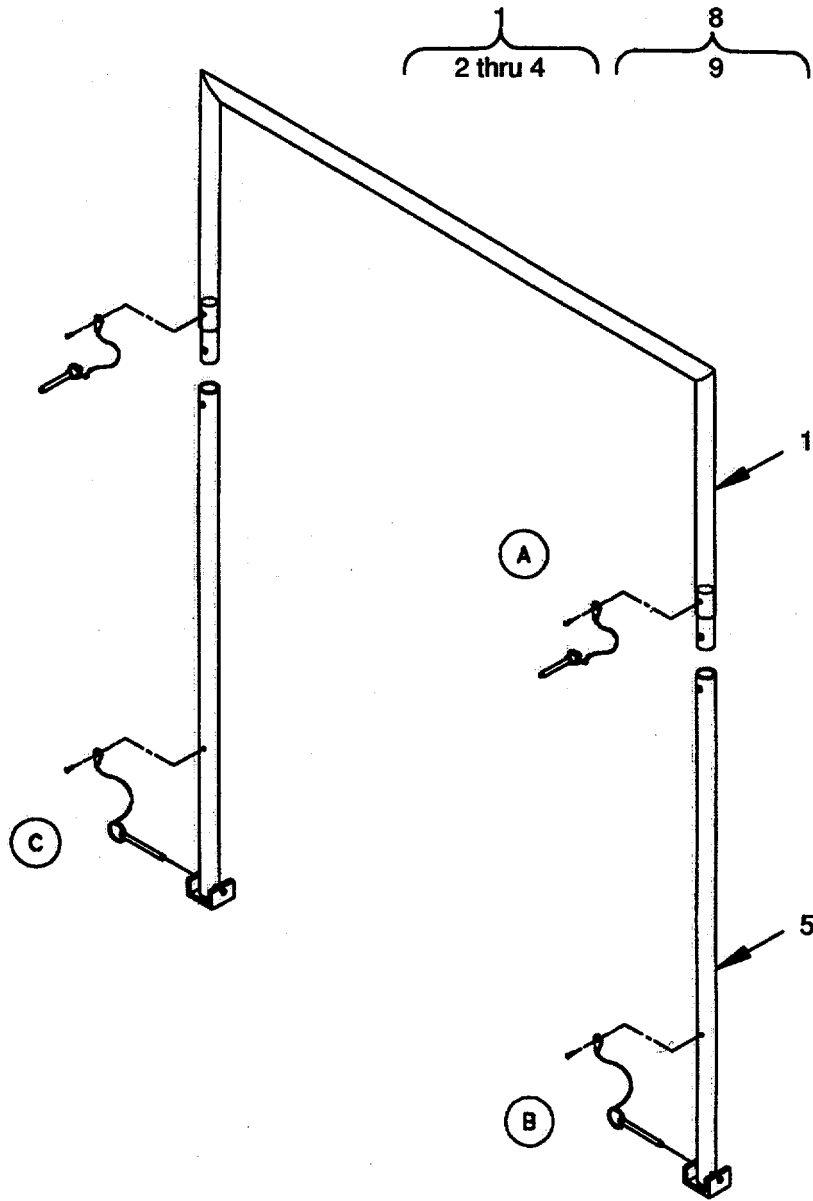

FIGURE 5. EXTERIOR FRAME ASSEMBLY (TEMPER)

SECTION II

TM 10-5411-203-23P

(1) ITEM NO	(2) SMR CODE	(3) CAGEC	(4) PART NUMBER	(5) DESCRIPTION AND USABLE ON CODES (UOC)	(6) QTY
				<b>GROUP 01</b>	
				<b>- TYPE II</b>	
				<b>FIG. 5</b>	
				<b>(TEMPER)</b>	
				<b>COMPLEXING KIT PASSAGEWAYS</b>	
				<b>EXTERIOR FRAME ASSEMBLY</b>	
1	XDOOO	81337	5-4-4197-1	HEADER ASSY SAND ..... UOC:FDD, FDE, FDK, FDL	1
1	XDOOO	81337	5-4-4197-2	HEADER ASSY GREEN ..... UOC:FDA, FDB, FDG, FDH	1
2	XDOZZ	96906	MS20613-6C24	RIVET, SOLID ..... UOC:FDA, FDB, FDD, FDE, FDG, FDH, FDK, FDL	2
3	XBOZZ	81337	5-4-5540-1	PIN W/LANYARD & TAB ..... UOC:FDA, FDB, FDD, FDE, FDG, FDH, FDK, FDL	2
4	XDOZZ	81337	5-4-4201-1	CONNECTING PIN ..... UOC:FDA, FDB, FDD, FDE, FDG, FDH, FDK, FDL	2
5	XDOZZ	81337	5-4-4200-1	FRAME, UPRIGHT SAND ..... UOC:FDD, FDE, FDK, FDL	2
5	XDOZZ	81337	5-4-4200-2	FRAME, UPRIGHT GREEN ..... UOC:FDA, FDB, FDG, FDH	2
6	XBOZZ	81349	M24243-6-A606F	RIVET, BLIND NON-STRUCTURAL, FILLED ..... CORE, CLOSED END 3/16 IN. DIA, 3/8 IN. GR UOC:FDA, FDB, FDD, FDE, FDG, FDH, FDK, FDL	2
7	XDOZZ	81337	5-4-6661-1	PIN & LANYARD ASSY ..... UOC:FDA, FDB, FDD, FDE, FDG, FDH, FDK, FDL	2
8	XDOZZ	81337	5-4-5891-1	FOOT, SWIVEL ASSY SAND ..... UOC:FDD, FDE, FDK, FDL	2
8	XDOZZ	81337	5-4-5891-2	FOOT, SWIVEL ASSY GREEN ..... UOC:FDA, FDB, FDG, FDH	2
9	XAOZZ	08524	DCT7900-12-D-5	CAPTIVE SCREW .250-28 SINGLE LEAD ..... UOC:FDA, FDB, FDD, FDE, FDG, FDH, FDK, FDL	1
				END OF FIGURE	

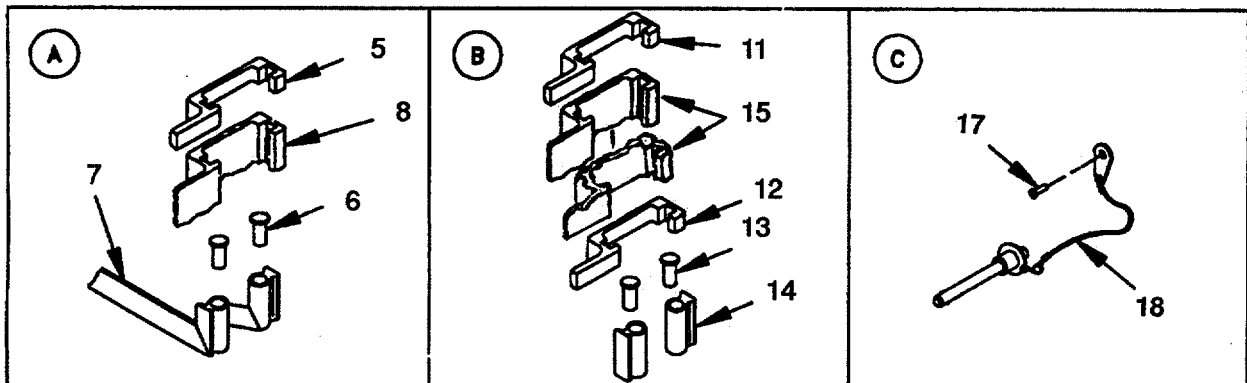
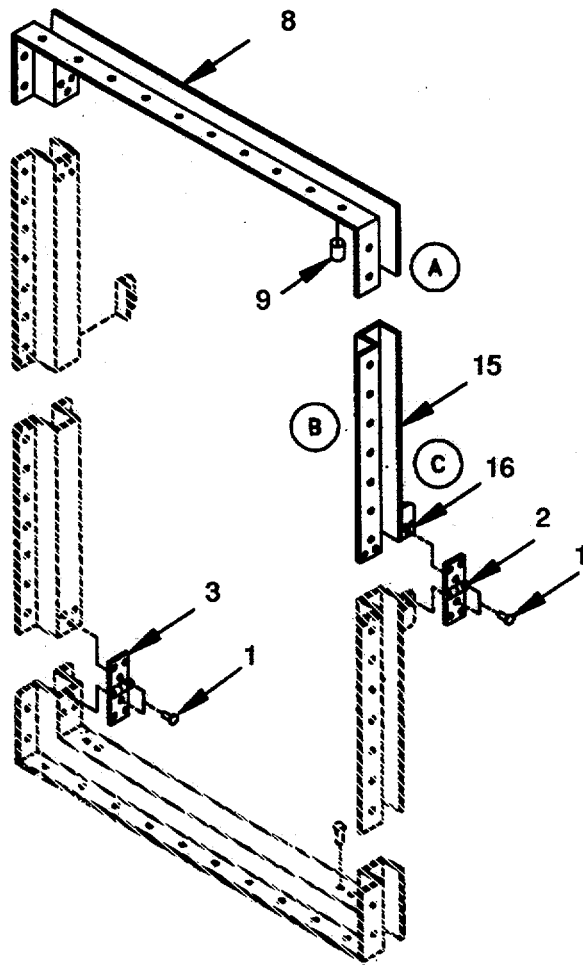
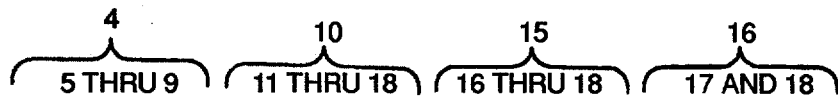

FIGURE 6. FRAME ASSEMBLY (ISO) ( Sheet 1 of 3 )

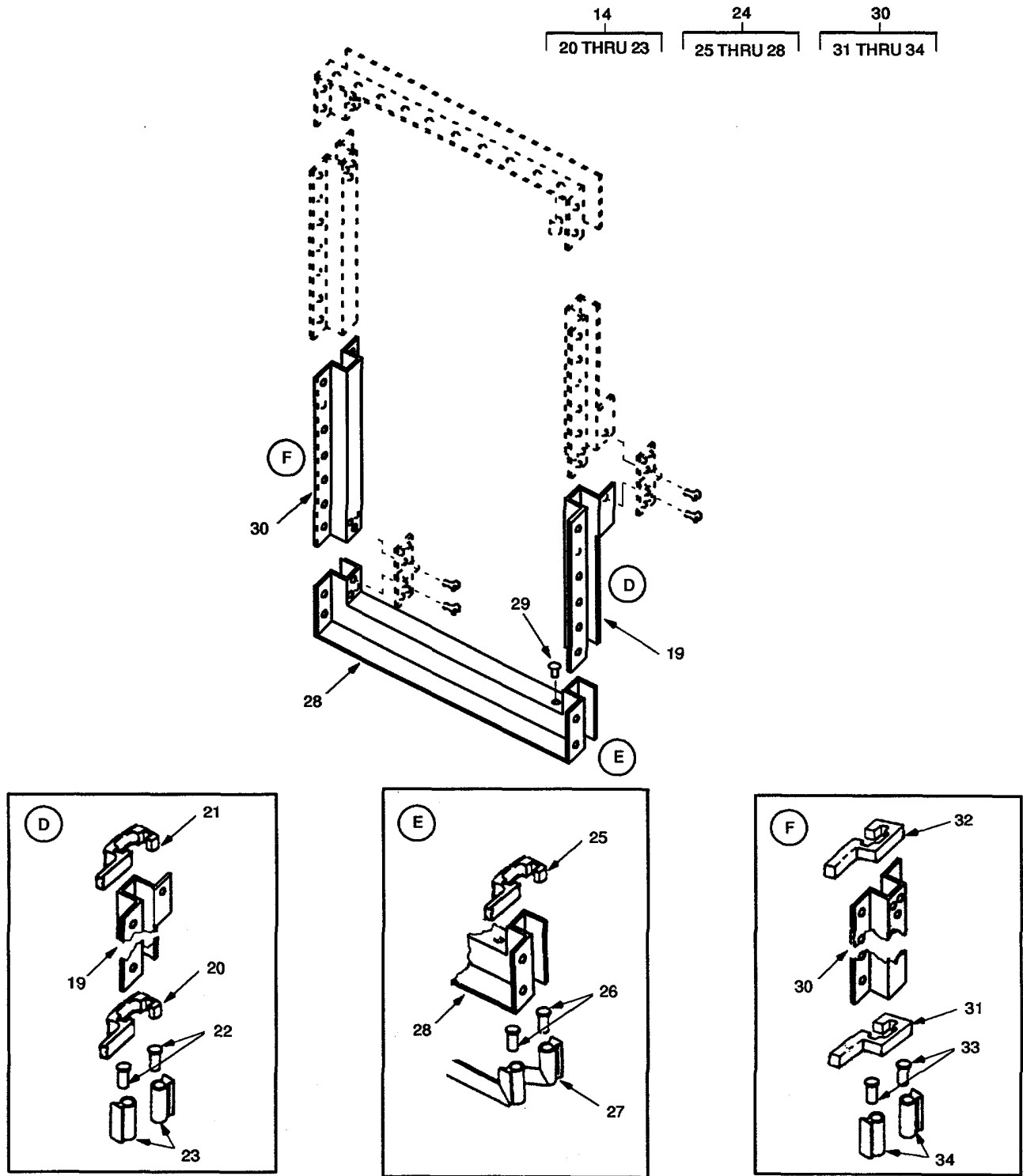

FIGURE 6. FRAME ASSEMBLY (ISO) (SHEET 2 OF 3).

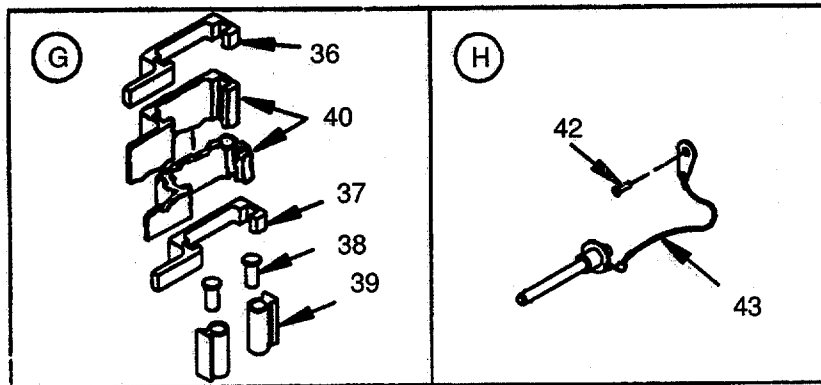
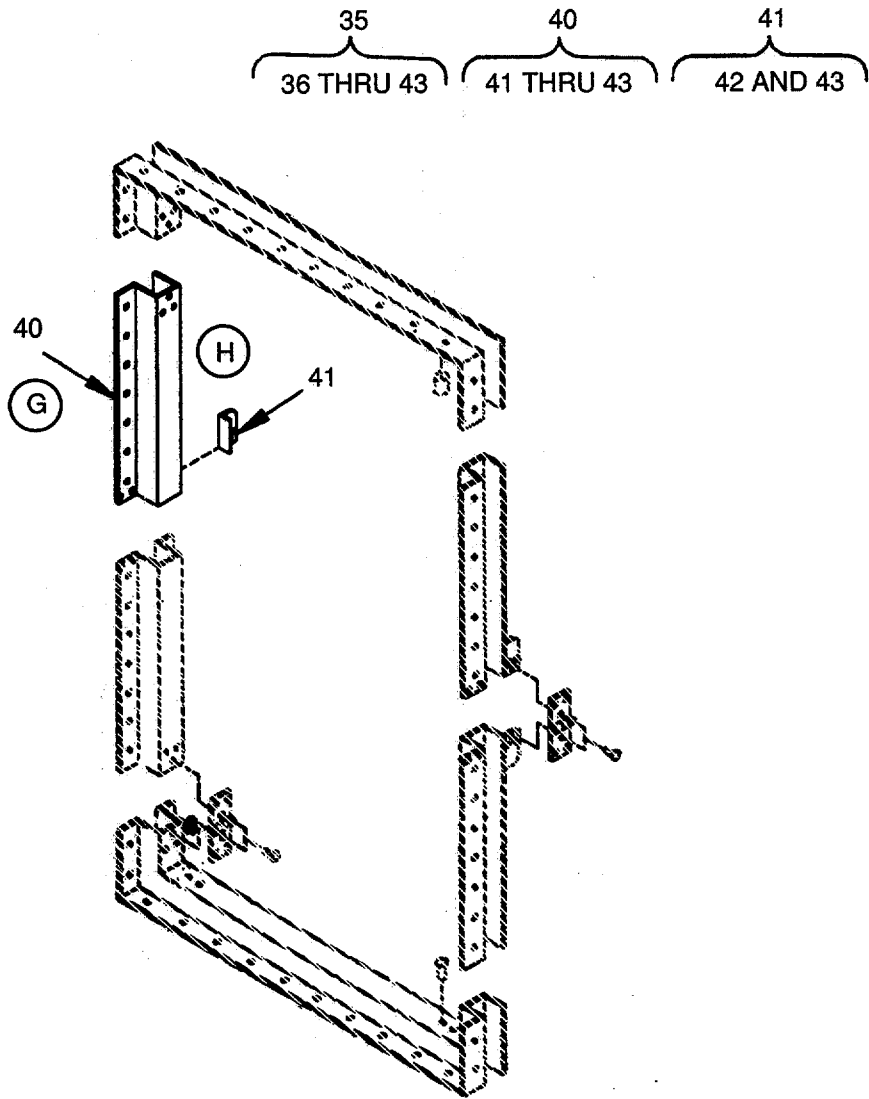

FIGURE 6. FRAME ASSEMBLY ( ISO ) ( Sheet 3 of 3 )



## SECTION II

TM 10-5411-203-23P

(1) ITEM NO	(2) SMR CODE	(3) CAGEC	(4) PART NUMBER	(5) DESCRIPTION AND USABLE ON CODES (UOC)	(6) QTY
				<b>GROUP 01      COMPLEXING KIT PASSAGEWAYS - TYPE II FIG. 6          FRAME ASSEMBLY (ISO)</b>	
1	XBOZZ	81349	M24243/6-A606F	RIVET,BLIND NON-STRUCTURAL,.....	48
				CLOSED END 3/16 IN. X 3/8 IN. GRIP UOC:FDA,FDB,FDD,FDE,FDG,FDH,FDK,FDL	
2	MOOZZ	81337	5-4-5538-1	HINGE MAKE FROM HINGE,P/N .....	4
				MS20001-14,CUT 1.5 IN. LG,FINISH IAW 5-4-04-1,SAND UOC:FDD,FDE,FDK,FDL	
2	MOOZZ	81337	5-4-5538-3	HINGE,ISO FRAME MAKE FROM HINGE,.....	4
				P/N MS20001-14,CUT 1.5 IN. LG, FINISH IAW 5-4-04-2,GREEN. UOC:FDA,FDB,FDG,FDH	
3	MOOZZ	81337	5-4-5538-4	HINGE,ISO FRAME MAKE FROM HINGE,.....	4
				P/N MS20001-14,CUT 2.5 IN. LG FINISH IAW 5-4-04-2,GREEN UOC:FDA,FDB,FDG,FDH	
3	MOOZZ	81337	5-4-5538-2	HINGE MAKE FROM HINGE,P/N .....	4
				MS20001-14,CUT 2.5 IN. LG,FINISH IAW 5-4-04-1,SAND UOC:FDD,FDE,FDK,FDL	
4	XBOOO	81337	5-4-8256-1	TOP ASSY SAND .....	1
				UOC:FDD,FDE,FDK,FDL	
4	XBOOO	81337	5-4-8256-2	TOP ASSY GREEN.....	1
				UOC:FDA,FDB,FDG,FDH	
5	XBOZZ	81337	5-4-5882-1	ENDCAP,CORNER JOINT .....	1
				UOC:FDA,FDB,FDD,FDE,FDG,FDH,FDK,FDL	
5	XBOZZ	81337	5-4-5882-2	ENDCAP,CORNER JOINT REVERSE .....	1
				UOC:FDA,FDB,FDD,FDE,FDG,FDH,FDK,FDL	
6	XBOZZ	81337	5-4-5539-1	JOINT SEAL.....	4
				UOC:FDA,FDB,FDD,FDE,FDG,FDH,FDK,FD	
7	MOOZZ	81337	5-4-4231-1	SEAL ASSY TOP, MAKE FROM.....	2
				SILCONE RUBBER PER ZZ-R- 765CL3D GRADE 50 COLOR BLACK UOC:FDA,FDB,FDD,FDE,FDG,FDH,FDK,FDL	
8	XBOZZ	81337	5-4-4205-1	FRAME, TOP,WELDMENT SAND .....	1
				UOC:FDD.FDE,FDK,FDL	
8	XBOZZ	81337	5-4-4205-2	FRAME, TOP,WELDMENT GREEN.....	1
				UOC:FDA,FDB,FDG,FDH	
9	XAOZZ	96906	MS14237-507-P375	BUSHING,SLEEVE PLAI PRESS FIT, .....	2
				REAM TYPE,.375 LG, .4375 DIA UOC:FDA,FDB,FDD,FDE,FDG,FDH,FDK,FDL	
10	XBOOO	81337	5-4-8252-1	SIDE ASSY UPPER RIGHT,SAND.....	1
				UOC:FDD,FDE,FDK,FDL	
10	XBOOO	81337	5-4-8252-2	SIDE ASSY UPPER RIGHT,GREEN.....	1
				UOC:FDA,FDB,FDG,FDH	
11	XBOZZ	81337	5-4-5882-2	ENDCAP,CORNER JOINT REVERSE .....	1
				UOC:FDA,FDB,FDD,FDE,FDG,FDH,FDK,FDL	
12	XBOZZ	81337	5-4-6474-1	ENDCAP,CENTER JOINT .....	1
				UOC:FDA.FDB,FDD,FDE,FDG,FDH.FDK,FDL	

## SECTION II

TM 10-5411-203-23P

(1) ITEM NO	(2) SMR CODE	(3) CAGEC	(4) PART NUMBER	(5) DESCRIPTION AND USABLE ON CODES (UOC)	(6) QTY
13	XBOZZ	81337	5-4-5539-1	JOINT SEAL..... UOC:FDA,FDB,FDD,FDE,FDG,FDH,FDK,FDL	4
14	MOOZZ	81337	5-4-4234-1	SEAL,SIDE MAKE FROM SILICONE ..... RUBBER PER ZZ-R-765CL3DGRADE 50 COLOR BLACK ... ..	2
15	XAOOO	81337	5-4-8248-1	UOC:FDA.FDB;FDD;FDE;FDG;FDH;FDK;FDL SIDE FRAME WELDMNT UPPER RIGHT,..... SAND	1
15	XAOOO	81337	5-4-8248-2	UOC:FDD.FDE,FDK.FDL SIDE FRAME WELDMNT UPPER RIGHT,..... GREEN	1
16	XAOZZ	81337	5-4-5881-2	UOC:FDA,FDB,FDG,FDH ANGLE MOUNT ASSY.....	1
17	XBOZZ	81349	M24243-6-A606F	UOC:FDA,FDB.FDD,FDE,FDG,FDH,FDK,FDL RIVET,BLIND NON-STRUCTURAL,..... CLOSED END 3/16 IN. X 3/8 IN. GRIP..	1
18	XBOZZ	81337	5-4-5540-1	UOC:FDA.FDB,FDD.FDE,FDG.FDH,FDK,FDL PIN W/LANYARD - PIN.....	1
19	XBOZZ	81337	5-4-8254-2	UOC:FDA,FDB,FDD,FDE,FDG,FDH,FDK,FDL SIDE ASSY LOWER RIGHT, GREEN.....	1
19	XBOZZ	81337	5-4-8254-1	UOC:FDA,FDB.FDG,FDH SIDE ASSY LOWER RIGHT, SAND.....	1
20	XBOZZ	81337	5-4-5882-1	UOC:FDD,FDE,FDK,FDL ENDCAP.CORNER JOINT.....	1
21	XBOZZ	81337	5-4-6474-1	UOC:FDA.FDB.FDD.FDE,FDG.FDH.FDK,FDL ENDCAP,CENTER JOINT.....	1
22	XBOZZ	81337	5-4-5539-1	UOC:FDA,FDB,FDD.FDE,FDG,FDH.FDK,FDL JOINT SEAL.....	4
23	MOOZZ	81337	5-4-4234-1	UOC:FDA,FDB.FDD,FDE.FDG,FDH.FDK,FDL SEAL,SIDE MAKE FROM SILICONE ..... RUBBER PER ZZ-R-765CL3B GRADE 50 COLOR BLACK	2
24	XAOOO	81337	5-4-8255-1	UOC:FDA,FDB.FDD,FDE,FDG,FDH.FDK,FDL BOTTOM ASSY SAND.....	1
24	XAOZZ	81337	5-4-8255-2	UOC:FDD,FDE,FDK,FDL BOTTOM ASSY GREEN.....	1
25	XBOZZ	81337	5-4-5882-2	UOC:FDA,FDB,FDG,FDH ENDCAP.CORNER JOINT REVERSE.....	1
25	XBOZZ	81337	5-4-5882-1	UOC:FDA,FDB,FDD,FDE,FDG,FDH,FDK,FDL ENDCAP,CORNER JOINT.....	1
26	XBOZZ	81337	5-4-5539-1	UOC:FDA,FDB,FDD,FDE,FDG,FDH,FDK,FDL JOINT SEAL.....	4
27	MOOZZ	81337	5-4-4231-1	UOC:FDA,FDB,FDD,FDE,FDG,FDH.FDK,FDL SEAL ASSY BOTTOM, MAKE FROM..... SILICONE RUBBER PER ZZ-R- 765CL3BGRADE50 COLOR BLACK	2
28	XBOZZ	81337	5-4-6477-1	UOC:FDA,FDB.FDD,FDE,FDG,FDH,FDK,FDL FRAME,BOTTOM,WLDMNT SAND.....	1
28	XBOZZ	81337	5-4-6477-2	UOC:FDD.FDE.FDK,FDL FRAME.BOTTOM,WLDMNT GREEN..... UOC:FDA,FDB,FDG,FDH	1

SECTION II

TM 10-5411-203-23P

(1) ITEM NO	(2) SMR CODE	(3) CAGEC	(4) PART NUMBER	(5) DESCRIPTION AND USABLE ON CODES (UOC)	(6) QTY
29	XBOZZ	81349	M5501/7-F2	CAP, PROTECTIVE .....	10
				UOC: FDA, FDB, FDD, FDE, FDG, FDH, FDK, FDL	
30	XBOOO	81337	5-4-8253-2	SIDE ASSY LOWER LEFT, GREEN .....	1
				UOC: FDA, FDB, FDG, FDH	
30	XBOOO	81337	5-4-8253-1	SIDE ASSY LOWER LEFT, SAND .....	1
				UOC: FDD, FDE, FDK, FDL	
31	XBOZZ	81337	5-4-5882-2	ENDCAP, CORNER JOINT REVERSE .....	1
				UOC: FDA, FDB, FDD, FDE, FDG, FDH, FDK, FDL	
32	XBOZZ	81337	5-4-6474-1	ENDCAP, CENTER JOINT .....	1
				UOC: FDA, FDB, FDD, FDE, FDG, FDH, FDK, FDL	
33	XBOZZ	81337	5-4-5539-1	JOINT SEAL .....	4
				UOC: FDA, FDB, FDD, FDE, FDG, FDH, FDK, FDL	
34	MOOZZ	81337	5-4-4234-1	SEAL, SIDE MAKE FROM SILICONE .....	2
				RUBBER PER ZZ-R-765CL3BGRADE50 COLOR BLACK	
				UOC: FDA, FDB, FDD, FDE, FDG, FDH, FDK, FDL	
35	XBOZZ	81337	5-4-8251-2	SIDE ASSY UPPER LEFT.....	1
				UOC: FDA, FDB, FDG, FDH	
35	XBOOO	81337	5-4-8251-1	SIDE ASSY UPPER LEFT, ISO FRAME .....	1
				UOC: FDD, FDE, FDK, FDL	
36	XBOZZ	81337	5-4-5882-1	ENDCAP, CORNER JOINT.....	1
				UOC: FDA, FDB, FDD, FDE, FDG, FDH, FDK, FDL	
37	XBOZZ	81337	5-4-6474-2	ENDCAP, CENTER JOINT.....	1
				UOC: FDA, FDB, FDD, FDE, FDG, FDH, FDK, FDL	
38	XBOZZ	81337	5-4-5539-1	JOINT SEAL.....	4
				UOC: FDA, FDB, FDD, FDE, FDG, FDH, FDK, FDL	
39	MOOZZ	81337	5-4-4234-1	SEAL, SIDE MAKE FROM SILICONE .....	2
				RUBBER PER ZZ-R-765CL3BGRADE50 COLOR BLACK	
				UOC: FDA, FDB, FDD, FDE, FDG, FDH, FDK, FDL	
40	XAOOO	81337	5-4-8247-1	SIDE FRAME WELDMENT UPPER LEFT, .....	1
				SAND	
				UOC: FDD, FDE, FDK, FDL	
40	XAOOO	81337	5-4-8247-2	SIDE FRAME WELDMENT UPPER LEFT, .....	1
				GREEN	
				UOC: FDA, FDB, FDG, FDH	
41	XAOZZ	81337	5-4-5881-1	ANGLE MOUNT ASSY.....	1
				UOC: FDA, FDB, FDD, FDE, FDG, FDH, FDK, FDL	
42	XBOZZ	81349	M24243/6-A606F	RIVET, BLIND NON-STRUCTURAL, .....	1
				CLOSED END 3/16 IN X 3/8 IN GRIP	
				UOC: FDA, FDB, FDD, FDE, FDG, FDH, FDK, FDL	
43	XBOZZ	81337	5-4-5540-1	PIN W/LANYARD & PIN.....	1
				UOC: FDA, FDB, FDD, FDE, FDG, FDH, FDK, FDL	

END OF FIGURE

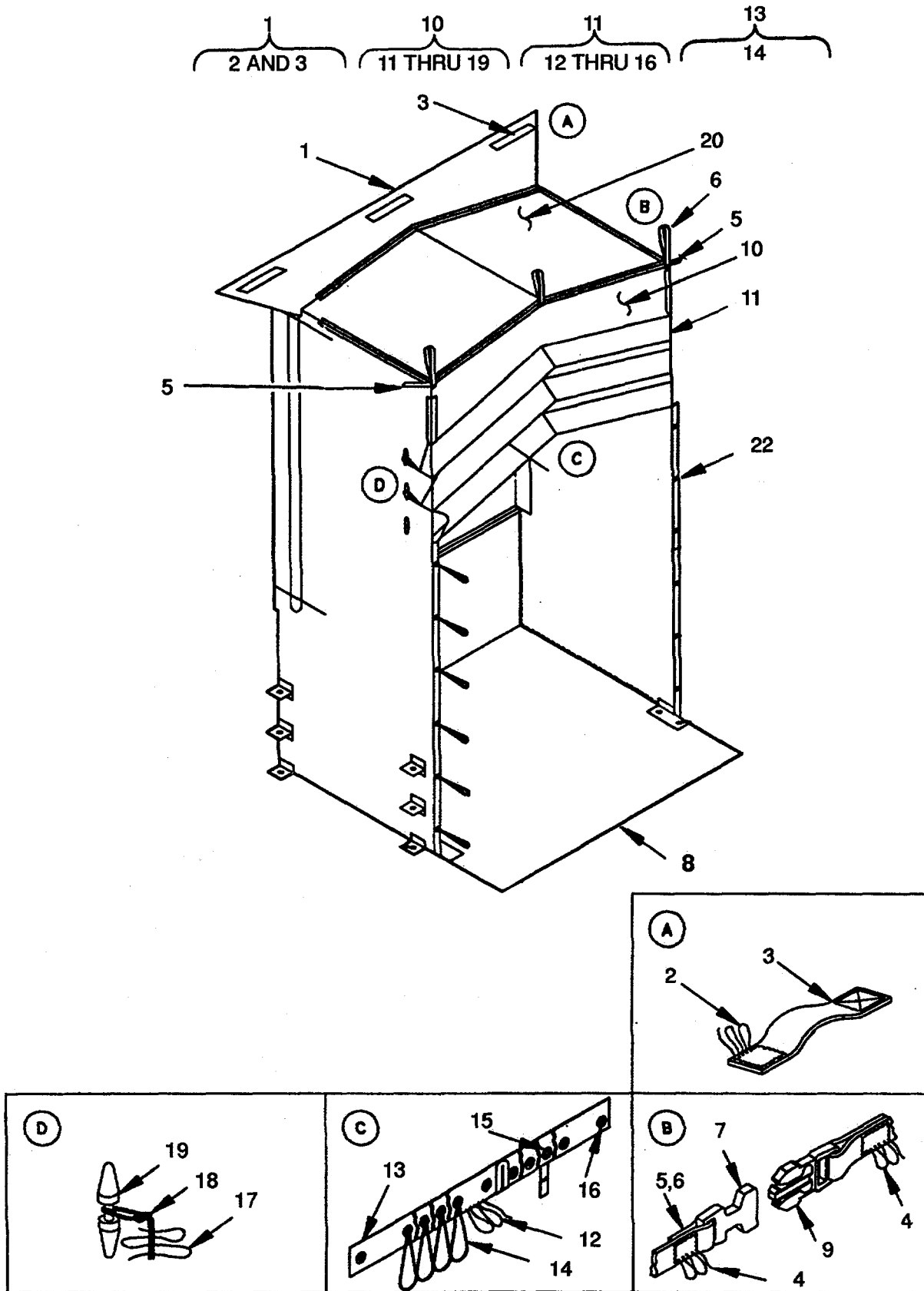

FIGURE 7. CONNECTOR ASSEMBLY (ISO TO TEMPER)

## SECTION II

TM 10-5411-203-23P

(1) ITEM NO	(2) SMR CODE	(3) CAGEC	(4) PART NUMBER	(5) DESCRIPTION AND USABLE ON CODES (UOC)	(6) QTY
				<b>GROUP 01</b>	
				<b>COMPLEXING KIT PASSAGEWAYS TYPE II</b>	
				<b>FIG 7</b>	
				<b>CONNECTOR ASSEMBLY (ISO TO TEMPER)</b>	
1	XBFZZ	81337	5-4-4193-1	WEATHER BARRIER SAND, ..... UOC: FDD, FDE, FDK, FDL	1
1	XBFZZ	81337	5-4-4193-2	WEATHER BARRIER GREEN..... UOC: FDA, FDB, FDG, FDH	1
2	XBOZZ	81348	VT-285TYICLISUBC LBSIZEF4	THREAD, POLYESTER SAND 33303 OR..... V GREEN 34094 PER FED-STD-595 UOC: FDA, FDB, FDD, FDE, FDG, FDH, FDK, FDL	
3	MFFZZ	81349	5-4-4193-3	HANDLE, WEA BARRIER MAKE FROM..... WEBBING, MIL-W-436G8 TYIII, 1 IN WIDE, CUT 8 IN LG, SAND 33303 OR GREEN 34094 PER FED-STD-595 UOC: FDA, FDB, FDD, FDE, FDG, FDH, FDK, FDL	3
4	XBOZZ	81348	VT-285TYICLISUBC LBSIZEF4	THREAD, POLYESTER THREAD, ..... V POLYESTER, SAND 33303 OR GREEN 34094 PER FED STD-595 UOC: FDA, FDB, FDD, FDE, FDG, FDH, FDK, FDL	
5	MFFZZ	81349	5-4-4181-16	STRAP ASSY MAKE FROM WEBBING, ..... NYLON, P/N MIL-W-43668 TYIII, 1 IN WIDE, CUT 8 IN LG, SAND 33303 OR GREEN 34094 PER FED STD-595 UOC: FDA, FDB, FDD, FDE, FDG, FDH, FDK, FDL	2
6	MFFZZ	81337	5-4-4181-1-37	FAST STRAP MAKE FROM WEBBING, ..... NYLON, P/N MIL-W-43668 TYIII, 1 IN WIDE, CUT 12 IN LG, SAND 33303 OR GREEN 34094 PER FED-STD-595 UOC: FDA, FDB, FDD, FDE, FDG, FDH, FDK, FDL	3
7	XDFZZ	81337	5-10-47 FEMALE1IN	BUCKLE, FEMALE 1 IN. WIDE..... UOC: FDA, FDB, FDD, FDE, FDG, FDH, FDK, FDL	5
8	XDFZZ	81337	5-4-4190-1	FLOOR ASSY SAND..... UOC: FDD, FDE, FDK, FDL	1
8	XDFZZ	81337	5-4-4190-2	FLOOR ASSY GREEN..... UOC: FDA, FDB, FDG, FDH	1
9	XBFZZ	81337	5-10-47 MALE1IN	BUCKLE, MALE 1 IN. WIDE ..... UOC: FDA, FDB, FDD, FDE, FDG, FDH, FDK, FDL	5
10	XBFZZ	81337	5-4-4182-1	CROWN ASSY SAND..... UOC: FDD, FDE, FDK, FDL	1
10	XBFZZ	81337	5-4-4182-2	CROWN ASSY GREEN ..... UOC: FDA, FDB, FDG, FDH	1
11	XBFZZ	81337	5-4-6664-1	FLAP, OUTSIDE BECKET SAND ..... UOC: FDD, FDE, FDK, FDL	3
11	XBFZZ	81337	5-4-6664-2	FLAP, OUTSIDE BECKET GREEN ..... UOC: FDA, FDB, FDG, FDH	3
12	XBOZZ	81348	VT-285TYICL1SUBC LBSIZEF4	THREAD, POLYESTER MIL-C-42356, ..... V COLOR SAND 33303 OR GREEN 34094 PER FED-STD-595, AS REQUIRED UOC: FDA, FDD, FDE, FDF, FDK, FDL, FDM, FDP	

SECTION II

TM 10-5411-203-23P

(1) ITEM NO	(2) SMR CODE	(3) CAGEC	(4) PART NUMBER	(5) DESCRIPTION AND USABLE ON CODES (UOC)	(6) QTY
13	MFFZZ	81337	5-4-6665-1	BECKET DETAIL, FLAP MAKE FROM ..... CORD, POLYESTER, SOLID BRAID, P/N MIL C-43256 5-32 IN. DIA., SAND 33303 OR GREEN 34094 PER MIL-STD-595, CUT TO LENGTH UOC: FDA, FDB, FDD, FDE, FDG, FDH, FDK, FDL	3
14	MOOZZ	81349	5-4-6668-1-1	CORD, POLYESTER MAKE FROM CORD, ..... POLYESTER, SOLID BRAID, P, N MIL-C- 43256 5/32 DIA SAND 33303 OR GREEN 34094 PER FED-STD-595, CUT TO LENGTH UOC: FDA, FD8, FDD, FDE, FDG, FDH, FDK, FDL	3
5	XBOZZ	81349	MTL-G-16491TYIII CL3N02	GROMMET ..... UOC: FDA, FDB, FDD, FDE, FDG, FDH, FDK, FDL	50
16	XBOZZ	81349	MIL-G-16491TYIII CL3N04	GROMMET ..... UOC: FDA, FDB, FDD, FDE, FDG, FDH, FDK, FDL	3
17	XBOZZ	B1348	YT-285TYISUBCLB SIZEF4	THREAD, POLYESTER SAND 33303 OR..... V GREEN 34094 PER FED-STD-595 UOC: FDA, FDB, FDD, FDE, FDG, FDH, FDK, FDL	
18	MFFZZ	81337	5-4-4184-21	CORD, POLYESTER MAKE FROM CORD, ..... POLYESTER, SOLID BRAID, P/N MIL-C- 43256 5-32 DIA, 6 IN LONG, SAND 33303 OR GREEN 34094 PER FED-STD-595 UOC: FDA, FDB, FDD, FDE, FDG, FDH, FDK, FDL	3
19	XBFZZ	81337	5-4-4152-1	TOGGLE, WOOD ..... UOC: FDA, FDB, FDD, FDE, FDG, FDH, FDK, FDL	10
20	MFFZZ	81337	5-4-4189-2	ROOF MAKE FROM CLOTH, COATED, P/N ..... MIL-C-43285 TYI CL3 FACE COLOR GREEN 34094 PER MIL-STD-595 UOC: FDA, FDB, FDG, FDH	1
20	MFFZZ	81337	5-4-4189-1	ROOF MAKE FROM CLOTH, COATED, P/N ..... MIL-C-43285 TYI CL3 FACE COLOR SAND 33303 PER FED-STD-595 UOC: FDD, FDE, FDK, FDL	1
21	XBFZZ	81337	5-4-4184-2	LEFT SIDE ASSY GREEN ..... UOC: FDA, FDB, FDG, FDH	1
21	XBFZZ	81337	5-4-4184-1	LEFT SIDE ASSY SAND..... UOC: FDD, FDE, FDK, FDL	1
22	XBFZZ	81337	5-4-4186-1	RIGHT SIDE ASSY SAND..... UOC: FDD, FDE, FDK, FDL	1
22	XBFZZ	81337	5-4-4186-2	RIGHT SIDE ASSY GREEN..... UOC: FDA, FDB, FDG, FDH	1

END OF FIGURE

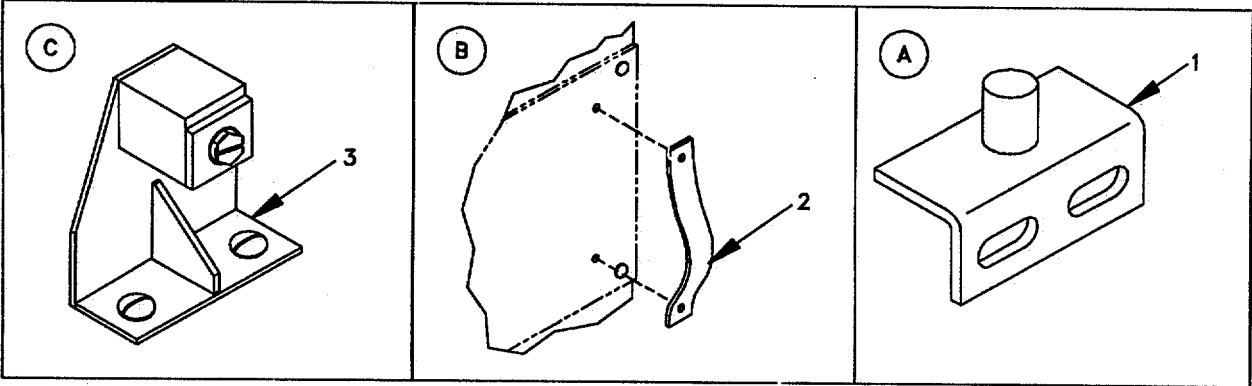
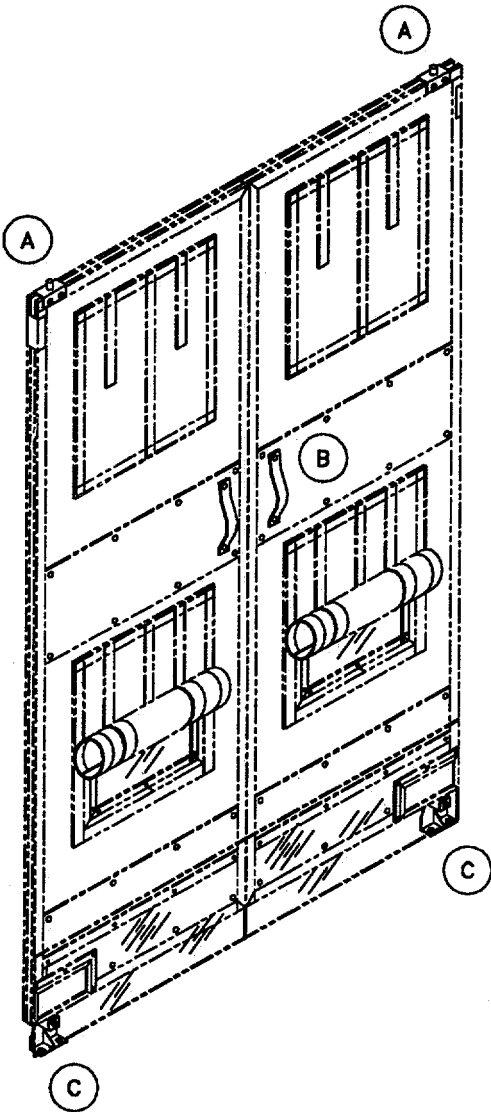

FIGURE 8 . BUMP THROUGH DOORS (ISO TO TEMPER)

SECTION II

TM 10-5411-203-23P

(1) ITEM NO	(2) SMR CODE	(3) CAGEC	(4) PART NUMBER	(5) DESCRIPTION AND USABLE ON CODES (UOC)	(6) QTY
-------------------	--------------------	--------------	-----------------------	--	------------

**GROUP 01      COMPLEXING KIT PASSAGEWAYS  
- TYPE II**

**FIG. 8          BUMP THROUGH DOORS  
(ISO TO TEMPER)**

1	XBOZZ	81337	5-4-4097-1	PIVOT, DOOR ASSY SAND..... UOC: FDK, FDL	2
1	XBOZZ	81337	5-4-4097-2	PIVOT, DOOR ASSY GREEN..... UOC: FDG, FDH	2
2	XBOZZ	81337	5-4-7400	NYLON HANDLE..... UOC: FDG, FDH, FDK, FDL	4
3	XBOZZ	81337	5-4-7401-1	PEDESTAL, DOOR ASSY SAND..... UOC: FDK, FDL	2
3	XBOZZ	81337	5-4-7401-2	PEDESTAL, DOOR ASSY GREEN..... UOC: FDG, FDH	2

END OF FIGURE



1  
2 THRU 7

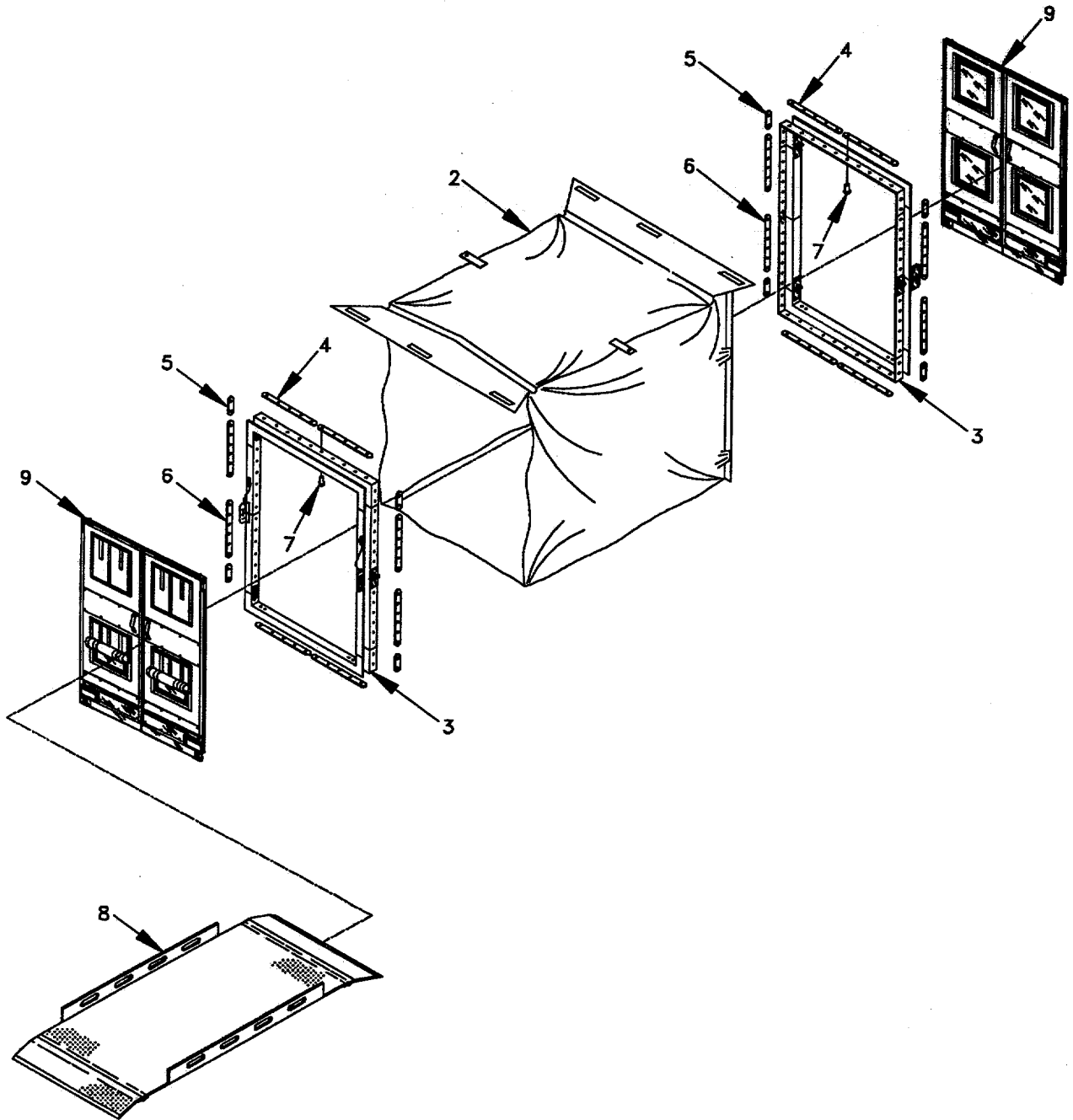

FIGURE 9 . PASSAGEWAYS - ISO TO ISO (TYPE 1)

SECTION II

TM 10-5411-203-23P

(1) ITEM NO	(2) SMR CODE	(3) CAGEC	(4) PART NUMBER	(5) DESCRIPTION AND USABLE ON CODES (UOC)	(6) QTY
-------------------	--------------------	--------------	-----------------------	--	------------

**GROUP 02      COMPLEXING KIT PASSAGEWAYS  
- TYPE I**

**FIG 9      PASSAGEWAYS - ISO TO ISO  
(TYPE I)**

1	XDOFF	81337	5-4-8259-1	FRAME-CONNECTOR ASSEMBLY, SAND ..... UOC: FDF, FDM, FDP	1
1	XDOFF	81337	5-4-8259-2	FRAME-CONNECTOR ASSEMBLY, GREEN ..... UOC: FDC, FDJ, FDN	1
2	XDOFF	81337	5-4-4202-1	CONNECTOR ASSY SAND ..... UOC: FDF, FDM, FDP	1
2	XDOFF	81337	5-4-420Z-2	CONNECTOR ASSY GREEN ..... UOC: FDC, FDJ, FDN	1
3	XBOFF	81337	5-4-4204-1	FRAME ASSY SAND ..... UOC: FDF, FDM, FDP	2
3	XBOFF	81337	5-4-4204-2	FRAME ASSY GREEN ..... UOC: FDC, FDJ, FDN	2
4	XBOZZ	81337	5-4-6662-1	RETAINER STRIP TOP AND BOTTOM, SAND ..... UOC: FDF, FDM, FDP	8
4	XBOZZ	81337	5-4-6662-2	RETAINER STRIP TOP AND BOTTOM, ..... GREEN UOC: FDC, FDJ, FDN	8
5	XBOZZ	81337	5-4-4213-1	RETAINER STRIP CORNER, SAND ..... UOC: FDF, FDM, FDP	8
5	XBOZZ	81337	5-4-4213-2	RETAINER STRIP CORNER, GREEN ..... UOC: FDC, FDJ, FDN	8
6	XBOZZ	81337	5-4-6663-1	RETAINER STRIP SIDE, SAND ..... UOC: FDF, FDM, FDP	8
6	XBOZZ	81337	5-4-6663-2	RETAINER STRIP SIDE, GREEN ..... UOC: FDC, FDJ, FDN	8
7	XDOZZ	81349	M24243/6-A606H	RIVET, BLIND NON-STRUCTURAL, FILLED ..... CORE, CLOSED END, 3/16 IN DIA, 3/8 IN GR UOC: FDC, FDF, FDJ, FDM, FDN, FDP	104
8	XDOOO	81337	5-4-5890-1	RAMP ASSY, ISO-ISO SAND ..... UOC: FDF, FDM, FDP	1
8	XDOOZ	81337	5-4-5890-2	RAMP ASSY, ISO-ISO GREEN ..... UOC: FDC, FDJ, FDN	1
9	XBOFF	81337	5-4-7532-1	DOORS, DOUBLE, TY III BUMP THROUGH, ..... WITH CARRYING CASE, SAND UOC: FDM	1
9	PDOFZ	81337	5-4-7532-2	DOOR , TENT BUMP THROUGH , WITH ..... CARRYING CASE, GREEN UOC: FDJ	1
9	XBOFF	81337	5-4-7532-1	DOORS, DOUBLE, TY III BUMP THROUGH, ..... WITH CARRYING CASE, SAND UOC: FDP	2
9	PDOFZ	81337	5-4-7532-2	DOOR, TENT DOUBLE BUMP THRU, TYPE ..... III, GREEN UOC: FDN	2

END OF FIGURE

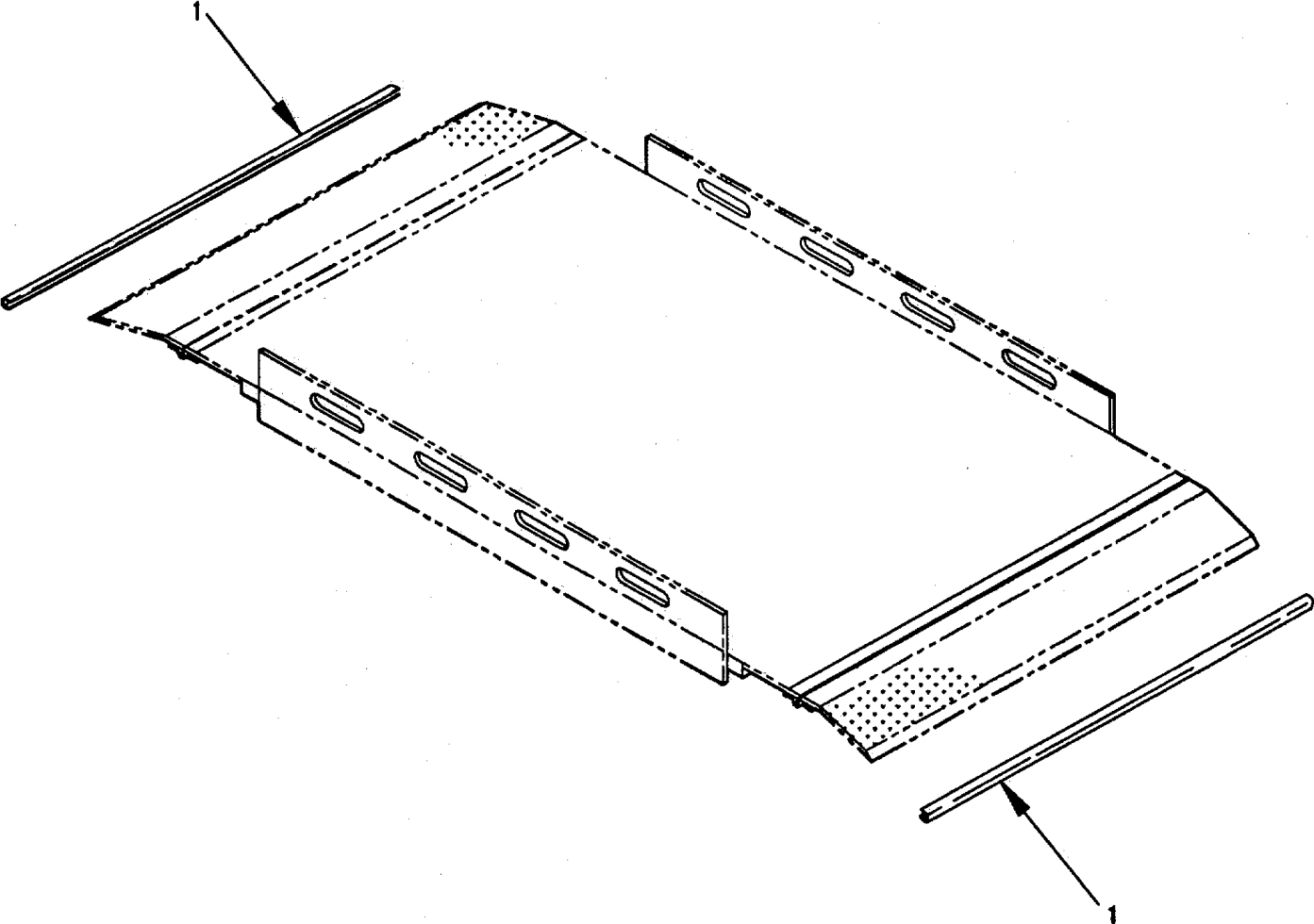

FIGURE 10 . RAMP ASSEMBLY (ISO TO ISO)

SECTION II

TM 10-5411-203-23P

(1) ITEM NO	(2) SMR CODE	(3) CAGEC	(4) PART NUMBER	(5) DESCRIPTION AND USABLE ON CODES (UOC)	(6) QTY
-------------------	--------------------	--------------	-----------------------	--	------------

**GROUP 02      COMPLEXING KIT PASSAGEWAYS  
- TYPE I  
FIG. 10      RAMP ASSEMBLY (ISO TO ISO)**

1 XBOZZ 81337 5-4-6475-1

EDGE PROTECTOR 47 INCHES LONG..... 2  
UOC: FDC, FDF, FDJ, FDM, FDN, FDP

END OF FIGURE

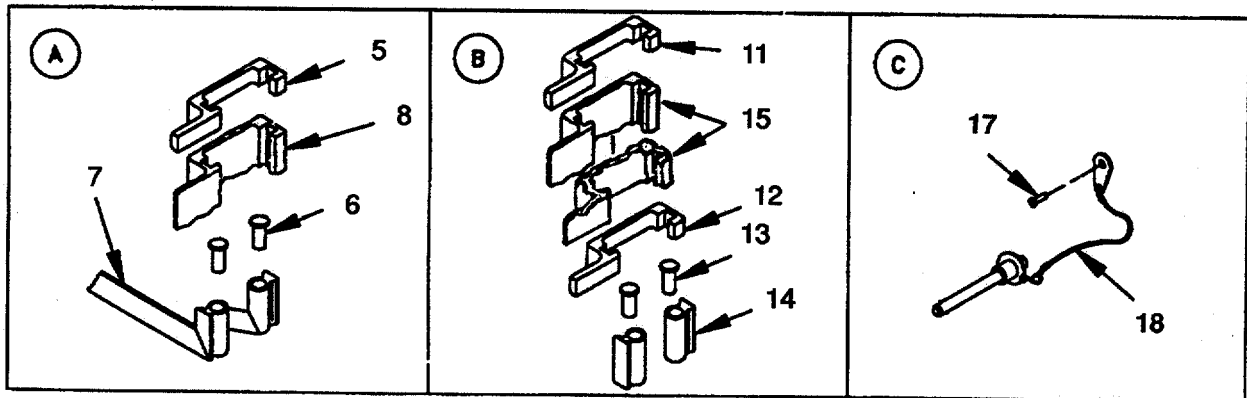
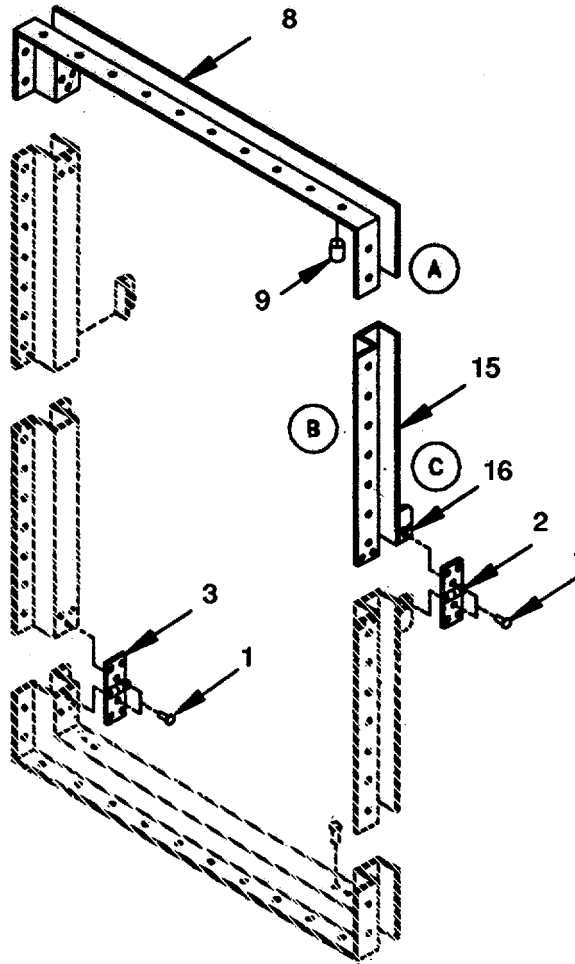
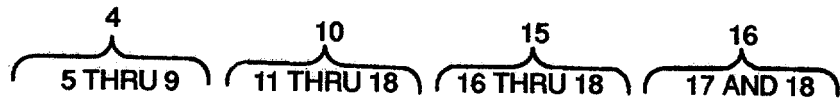

FIGURE 11. FRAME ASSEMBLY (ISO) (Sheet 1 of 3)

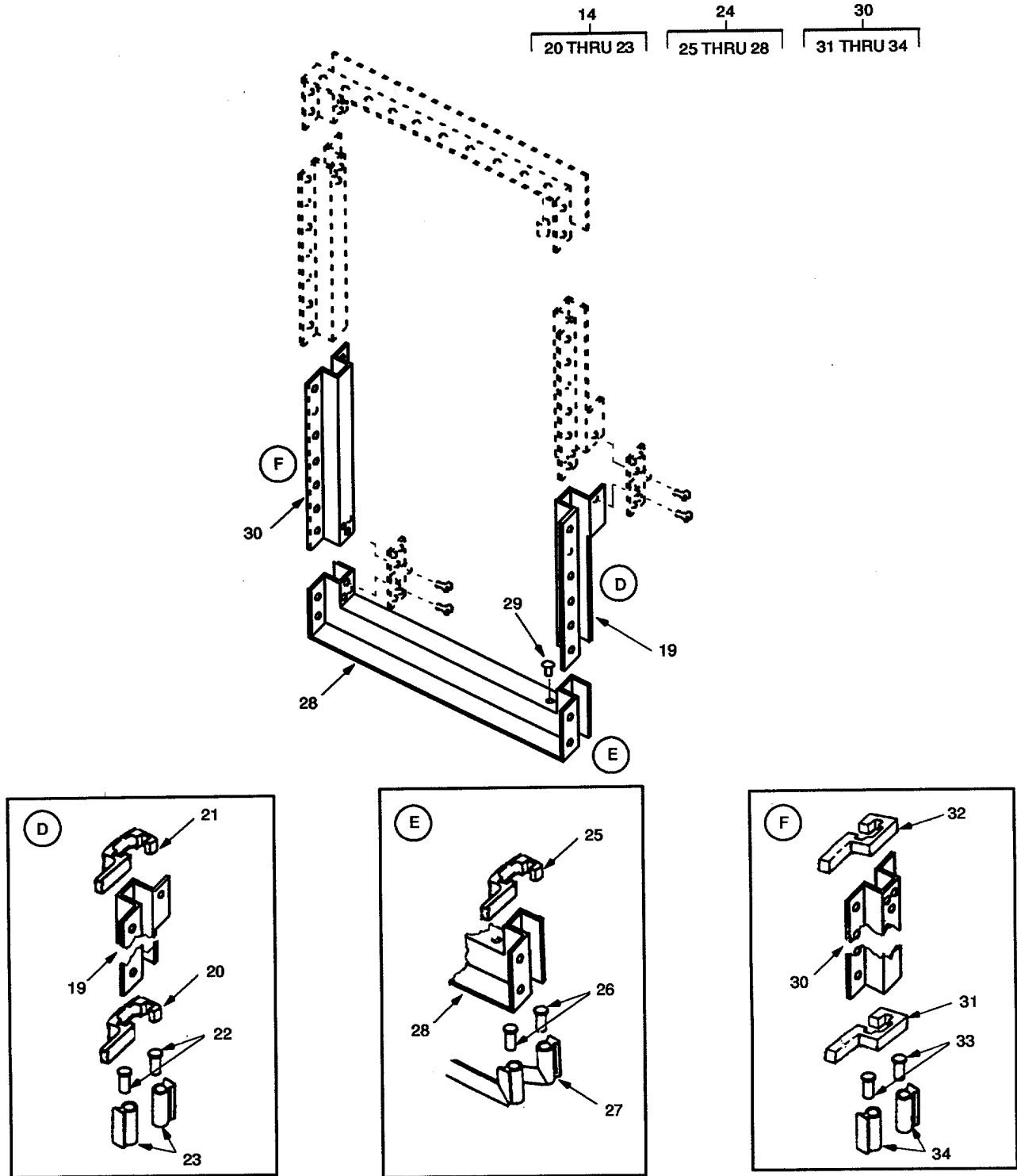

FIGURE 11. FRAME ASSEMBLY (ISO) (SHEET 2 OF 3).

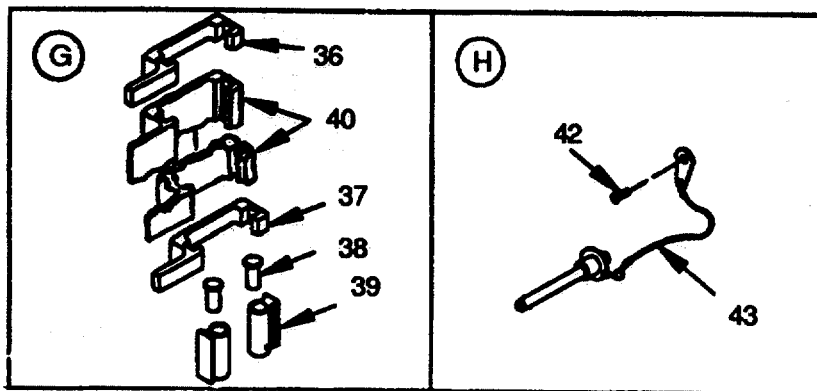
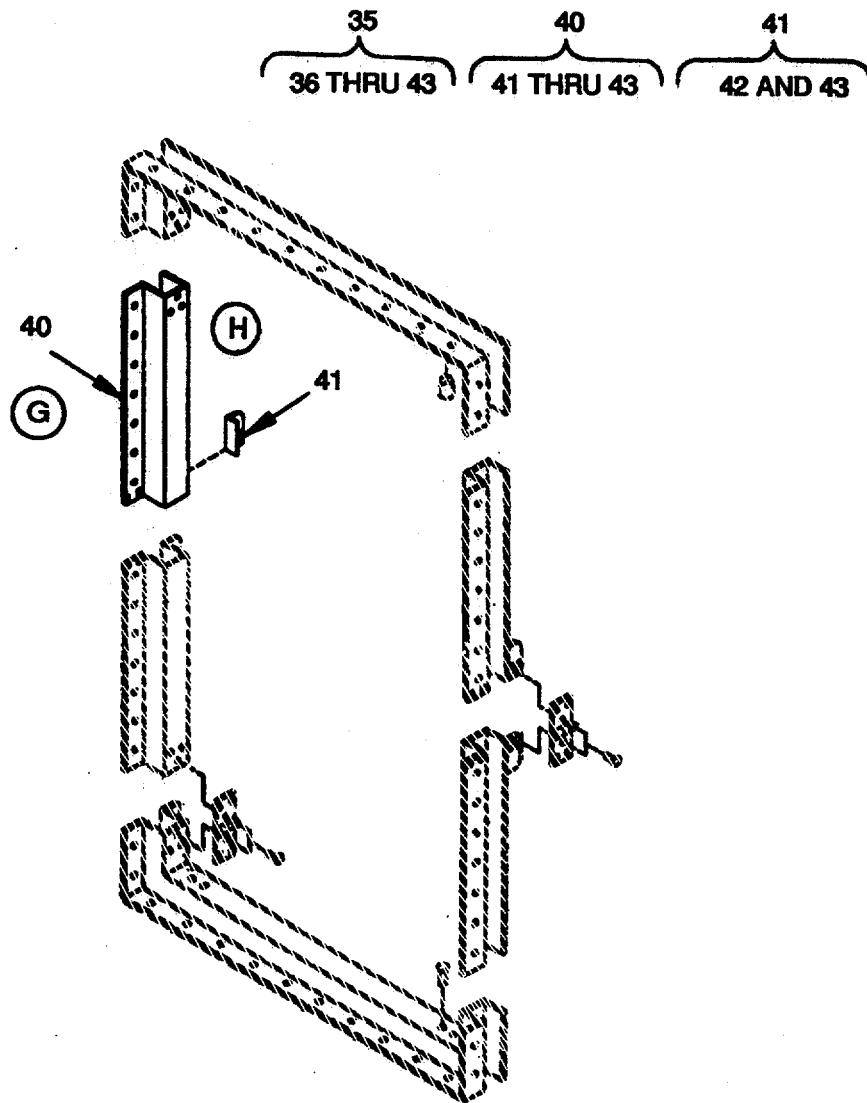

FIGURE 11. FRAME ASSEMBLY (ISO) (SHEET 3 Of 3)

## SECTION II

TM 10-5411-203-23P

(1) ITEM NO	(2) SMR CODE	(3) CAGEC	(4) PART NUMBER	(5) DESCRIPTION AND USABLE ON CODES (UOC)  GROUP 02  COMPLEXING KIT PASSAGEWAYS - TYPE I  FIG 11  FRAME ASSEMBLY (ISO)	(6) QTY
1	XBOZZ	81349	M24243-6-A606F	RIVET, BLIND NON-STRUCTURAL, ..... FILLED CORE, CLOSED END 3-16 IN DIA, 3-8. IN GR UOC: FDC, FDF, FDJ, FDM, FDN, FDP	48
2	MOOZZ	81337	5-4-5538-1	HINGE MAKE FROM HINGE, P/N ..... MS20001-14, CUT 1.5 IN LG, FINISH IAW 5-4-04-1, SAND UOC: FDF, FDM, FDP	4
2	MOOZZ	81337	5-4-5538-3	HINGE, MAKE FROM HINGE, P/N ..... MS20001-14, CUT 1.5 IN. LG, FINISH IAW 5-4-04-2, GREEN UOC: FDC, FDJ, FDN	4
3	MOOZZ	81337	5-4-5538-2	HINGE MAKE FROM HINGE, P/N ..... MS20001-14, CUT 2.5 IN. LG, FINISH IAW 5-4-04-1, SAND UOC: FDF, FDM, FDP	4
3	MOOZZ	81337	5-4-5538-4	HINGE, MAKE FROM HINGE, P/N ..... MS20001-14, CUT 2.5 IN LG, FINISH IAW 5-4-04-2, GREEN UOC: FDC, FDJ, FDN	4
4	XBO00	81337	5-4-8256-1	TOP FRAME ASSY SAND ..... UOC: FDF, FDM, FDP	1
4	XAO00	81337	5-4-8256-2	TOP FRAME ASSY GREEN ..... UOC: FDC, FDJ, FDN	1
5	XBOZZ	81337	5-4-5882-1	ENDCAP, CORNER JOINT ..... UOC: FDC, FDF, FDJ, FDM, FDN, FDP	1
5	XBOZZ	81337	5-4-5882-2	ENDCAP, CORNER JOINT REVERSE ..... UOC: FDC, FDF, FDJ, FDM, FDN, FDP	1
6	XBOZZ	81337	5-4-5539-1	JOINT SEAL..... UOC: FDC, FDF, FDJ, FDM, FDN, FDP	4
7	MOOZZ	81337	5-4-4231-1	SEAL ASSY TOP, MAKE FROM..... SILICONE RUBBER PER ZZ-R- 765CL3BGRADE50 COLOR BLACK UOC: FDC, FDF, FDJ, FDM, FDN, FDP	2
8	XBOZZ	81337	5-4-4205-1	FRAME, TOP, WELDMENT SAND ..... UOC: FDF, FDM, FDP	1
8	XBOZZ	81337	5-4-4205-2	FRAME, TOP, WELDMENT GREEN..... UOC: FDC, FDJ, FDN	1
9	XBOZZ	96906	MS14237-507-P375	BUSHING, SLEEVE PLAIN PRESS FIT, ..... REAM TYPE, .375 LG, .4375 DIA UOC: FDC, FDF, FDJ, FDM, FDN, FDP	2
10	XBO00	81337	5-4-8252-1	SIDE ASSY UPPER RIGHT, SAND..... UOC: FDF, FDM, FDP	1
10	XBOZZ	81337	5-4-8252-2	SIDE ASSY UPPER RIGHT, GREEN..... UOC: FDC, FDJ, FDN	1
11	XBOZZ	81337	5-4-5882-2	ENDCAP, CORNER JOINT REVERSE ..... UOC: FDC, FDF, FDJ, FDM, FDN, FDP	1



SECTION II

TM 10-5411-203-23P

(1) ITEM NO	(2) SMR CODE	(3) CAGEC	(4) PART NUMBER	(5) DESCRIPTION AND USABLE ON CODES (UOC)	(6) QTY
12	XBOZZ	81337	5-4-6474-1	ENDCAP, CENTER JOINT..... UOC: FDC, FDF, FDJ, FDM, FDN, FDP	1
13	XBOZZ	81337	5-4-5539-1	SEAL, JOINT..... UOC: FDC, FDF, FDJ, FDM, FDN, FDP	4
14	MOOZZ	81337	5-4-4234-1	SEAL, SIDE MAKE FROM SILICONE ..... RUBBER PER ZZ-R-765CL3BGRADE50 COLOR BLACK..... UOC: FDC, FDF, FDJ, FDM, FDN, FDP	2
15	XDOOO		81337	5-4-8248-1SIDE FRAME WELDMENT UPPER RIGHT, SAND..... UOC: FDF, FDM, FDP	1
15	XDOOO		81337	5-4-8248-2SIDE FRAME WELDMENT UPPER RIGHT, GREEN ..... UOC: FDC, FDJ, FDN	1
16	XAOZZ	81337	5-4-5881-2	ANGLE MOUNT ASSY..... UOC: FDC, FDF, FDJ, FDM, FDN, FDP	1
17	XDOZZ	81349	M24243/6-A606F	RIVET, BLIND NON-STRUCTURAL, ..... CLOSED END 3-16 IN. X 3-8 IN. GRIP.. UOC: FDC, FDF, FDJ, FDM, FDN, FDP	1
18	XDOZZ	81337	5-4-5540-1	PIN W/LANYARD & TAB..... UOC: FDC, FDF, FDJ, FDM, FDN, FDP	1
19	XBOZZ	81337	5-4-8254-1	SIDE ASSY LOWER RIGHT, SAND..... UOC: FDF, FDM, FDP	1
19	XAOZZ	81337	5-4-8254-2	SIDE ASSY LOWER RIGHT, GREEN..... UOC: FDC, FDJ, FDN	1
20	XBOZZ	81337	5-4-5882-1	ENDCAP, CORNER JOINT ..... UOC: FDC, FDF, FDJ, FDM, FDN, FDP	1
21	XBOZZ	81337	5-4-6474-2	ENDCAP, CENTER JOINT..... UOC: FDC, FDF, FDJ, FDM, FDN, FDP	1
22	XBOZZ	81337	5-4-5539-1	JOINT SEAL..... UOC: FDC, FDF, FDJ, FDM, FDN, FDP	4
23	MOOZZ	81337	5-4-4234-1	SEAL, SIDE MAKE FROM SILICONE ..... RUBBER PER ZZ-R-765CL3BGRADE50 COLOR BLACK..... UOC: FDC, FDF, FDJ, FDM, FDN, FDP	2
24	XA0ZZ	81337	5-4-8255-2	BOTTOM ASSY GREEN..... UOC: FDC, FDJ, FDN	1
24	XBOOO	81337	5-4-8255-1	BOTTOM ASSY SAND..... UOC: FDF, FDM, FDP	1
25	XBOZZ	81337	5-4-5882-2	ENDCAP, CORNER JOINT REVERSE., ..... UOC: FDC, FDF, FDJ, FDM, FDN, FDP	1
25	XBOZZ	81337	5-4-5882-1	ENDCAP, CORNER JOINT ..... UOC: FDC, FDF, FDJ, FDM, FDN, FDP	1
26	XDOZZ	81337	5-4-5539-1	SEAL, JOINT..... UOC: FDC, FDF, FDJ, FDM, FDN, FDP	4
27	MOOZZ	81337	5-4-4231-1	SEAL ASSY MAKE FROM SILICONE ..... RUBBER PER ZZ-R-765CL3BGRADE50 COLOR BLACK..... UOC: FDC, FDF, FDJ, FDM, FDN, FDP	2
28	XBOZZ	81337	5-4-6477-1	FRAME, BOTTOM, WELDMENT SAND ..... UOC: FDF, FDM, FDP	1
28	XBOZZ	81337	5-4-6477-2	FRAME, BOTTOM, WLDMNT GREEN ..... UOC: FDF, FDM, FDP	1

SECTION II

TM 10-5411-203-23P

(1) ITEM NO	(2) SMR CODE	(3) CAGEC	(4) PART NUMBER	(5) DESCRIPTION AND USABLE ON CODES (UOC)	(6) QTY
29	XBOZZ	81349	M5501/7-F2	UOC: FDC, FDJ, FDN CAP, PROTECTIVE .....	4
30	XAOZZ	81337	5-4-8253-2	UOC: FDC, FDF, FDJ, FDM, FDN, FDP SIDE ASSY LOWER LEFT, GREEN .....	1
30	XDOOO	81337	5-4-8253-1	UOC: FDC, FDJ, FDN SIDE ASSY LOWER LEFT, SAND .....	1
31	XBOZZ	81337	5-4-6474-1	UOC: FDF, FDM, FDP ENDCAP, CORNER JOINT .....	1
32	XBOZZ	81337	5-4-8253-2	UOC: FDC, FDF, FDJ, FDM, FDN, FDP ENDCAP, CENTER JOINT .....	1
33	XBQZZ	81337	5-4-5539-1	UOC: FDC, FDF, FDJ, FDM, FDN, FDP SEAL, JOINT .....	4
34	MOOZZ	81337	5-4-4234-1	UOC: FDC, FDF, FDJ, FDM, FDN, FDP SEAL, SIDE MAKE FROM SILICONE .....	2
				RUBBER PER ZZ-R-765CL3B6GRADE5Q COLOR BLACK .....	
35	XBOZZ	81337	5-4-8251-2	UOC: FDC, FDF, FDJ, FDM, FDN, FDP SIDE ASSY UPPER LEFT, GREEN .....	1
35	XAOZZ	81337	5-4-8251-1	UOC: FDC, FDJ, FDN SIDE ASSY UPPER LEFT, SAND .....	1
36	XBOZZ	81337	5-4-5882-1	UOC: FDF, FDM, FDP ENDCAP, CORNER JOINT .....	1
37	XBOZZ	81337	5-4-6474-2	UOC: FDC, FDF, FDJ, FDM, FDN, FDP ENDCAP, CENTER JOINT .....	1
38	XBOZZ	81337	5-4-5539-1	UOC: FDC, FDF, FDJ, FDM, FDN, FDP SEAL, JOINT .....	4
39	MOOZZ	81337	5-4-4234-1	UOC: FDC, FDF, FDJ, FDM, FDN, FDP SEAL, SIDE MAKE FROM SILICONE .....	2
				RUBBER PER ZZ-R-765CL3BGRADE50 COLOR BLACK .....	
40	XBOOO	81337	5-4-8247-1	UOC: FDC, FDF, FDJ, FDM, FDN, FDP SIDE FRAME WELDMENT UPPER LEFT, .....	1
				SAND .....	
40	XBOOO	81337	5-4-8247-2	UOC: FDF, FDM, FDP SIDE FRAME WELDMENT UPPER LEFT, .....	1
				GREEN .....	
41	XAOZZ	81337	5-4-5881-1	UOC: FDC, FDJ, FDN ANGLE MOUNT ASSY .....	1
42	XBOZZ	81349	M24243/6-A606F	UOC: FDC, FDF, FDJ, FDM, FDN, FDP RIVET, BLIND NON-STRUCTURAL, .....	1
				CLOSED END 3-16 IN X 3/8 IN GRIP UOC: FDC, FDF, FDJ, FDM, FDN, FDP	
43	XBOZZ	81337	5-4-5540-1	PIN W/LANYARD & TAB .....	1
				UOC: FDC, FDF, FDJ, FDM, FDN, FDP	

END OF FIGURE

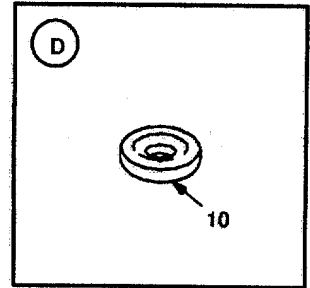
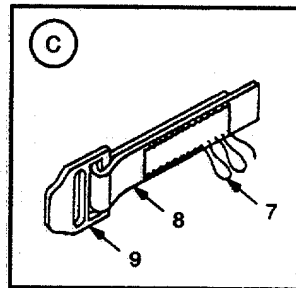
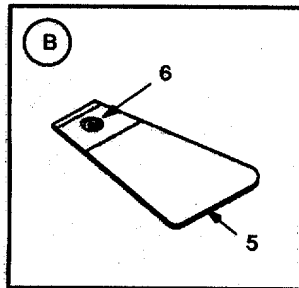
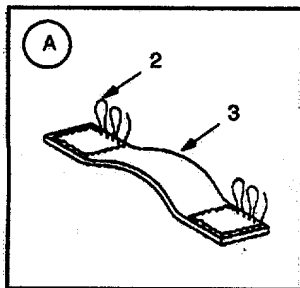
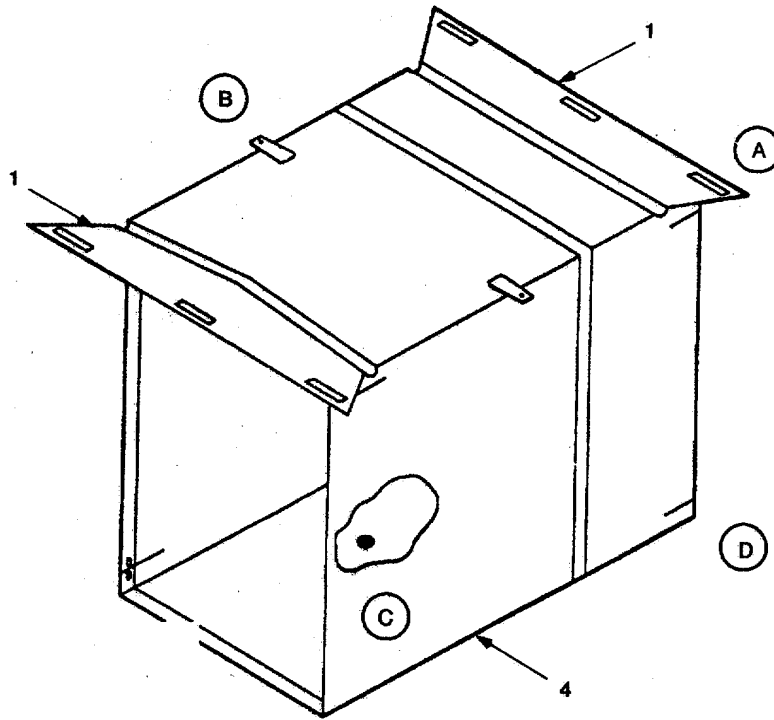
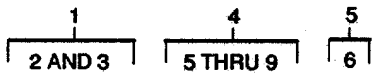

FIGURE 12 . CONNECTOR ASSEMBLY (ISO TO ISO).

SECTION II

TM 10-5411-203-23P

(1) ITEM NO	(2) SMR CODE	(3) CAGEC	(4) PART NUMBER	(5) DESCRIPTION AND USABLE ON CODES (UOC)  GROUP 02  COMPLEXING KIT PASSAGEWAYS - TYPE I  FIG 12  CONNECTOR ASSEMBLY	(6) QTY
1	XBFZZ	81337	5-4-4193-1	WEATHER BARRIER SAND..... UOC: FDF, FDM, FDP	1
1	XBFZZ	81337	5-4-4193-2	WEATHER BARRIER GREEN..... UOC: FDC, FDJ, FDN	1
2	XBOZZ	81348	VT-285TYICL1SUBC LBSIZEF4	THREAD, POLYESTER SAND 33303 OR..... V GREEN 34094 PER FED-STD-595 UOC: FDC, FDF, FDJ, FDM, FDN, FDP	
3	MFFZZ	81349	5-4-4193-3	HANDLE, WEA BARRIER MAKE FROM..... WEBBING, MIL-W-43668 TYIII 1 IN WIDE, CUT 8 IN LG LOR 33303 PER FED STD-595 UOC: FDC, FDF, FDJ, FDM, FDN, FDP	6
4	XDFFF	81337	5-4-4203-1	BODY ASSY CONNECTOR, SAND..... UOC: FDF, FDM, FDP	1
4	XBFFF	81337	5-4-4203-2	BODY ASSY CONNECTOR, GREEN..... UOC: FDC, FDJ, FDN	1
5	MFFZZ	81337	5-4-4202-1-8	TAPE, COTTON MAKE FROM TAPE, ..... TEXTILE, COTTON, P/N MIL-T-43566 TYI CL4, CUT TO SIZE, SAND..... UOC: FDF, FDM, FDP	2
5	MFF2Z	81337	5-4-4288-2	CHAPE TENSION MAKE FROM TAPE, ..... TEXTILE, COTTON, P/N MIL-T-43566 TYI CL4, CUT TO SIZE, GREEN..... UOC: FDC, FDJ, FDN	2
6	XBOZZ	81349	MIL-G-16491TYIII CL3NO4	GROMMET..... UOC: FDC, FDF, FDJ, FDM, FDN, FDP	1
7	XBOZZ	81348	VT-285TYLCL1SUBC LBSIZEF4	THREAD, POLYESTER TAN 33303 OR..... V GREEN 34094 PER FED-STD-595..... UOC: FDC, FDF, FDJ, FDM, FDN, FDP	
8	MFFZZ	81337	5-4-4203-1-16	STRAP, CONNECTOR MAKE FROM..... WEBBING, BULKED, P/N MIL-W-43688 TYIII 1 IN W, CUT 4 LG, COLOR SAND 33303 PER FED-STD-595..... UOC: FDF, FDM, FDP	8
8	MFFZZ	81337	5-4-4203-2-16	STRAP, CONNECTOR MAKE FROM..... WEBBING, BULKED, P/N MIL-W-43668..... TYIII 1 IN WIDE, CUT IN LG, COLOR GREEN 34094 PER FED-STD-595..... UOC: FDC, FDJ, FDN	8
9	XBFZZ	02768	SLL	BUCKLE, 1 INCH 1 INCH WIDE..... UOC: FDC, FDF, FDJ, FDM, FDN, FDP	8
10	XBOZZ	81349	MIL-6-16491TYIII CL3NO6	GROMMET..... UOC: FDC, FDF, FDJ, FDM, FDN, FDP	1

END OF FIGURE

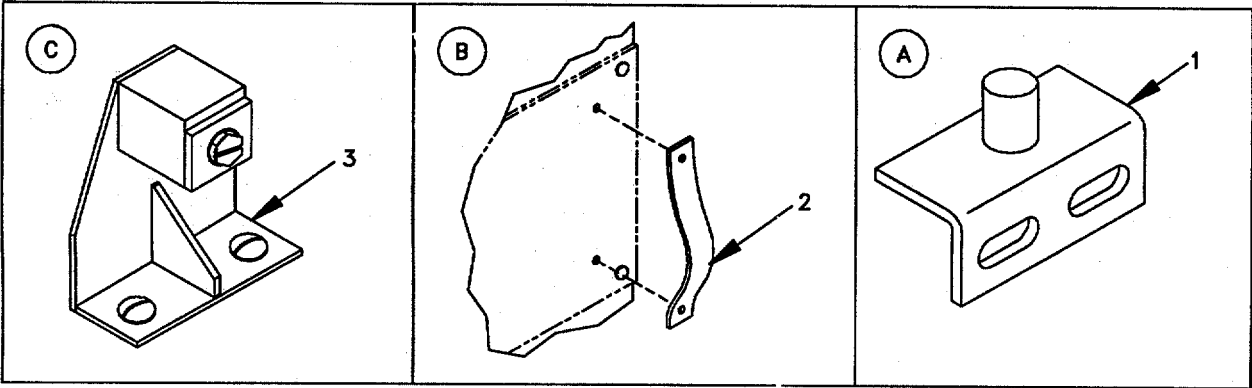
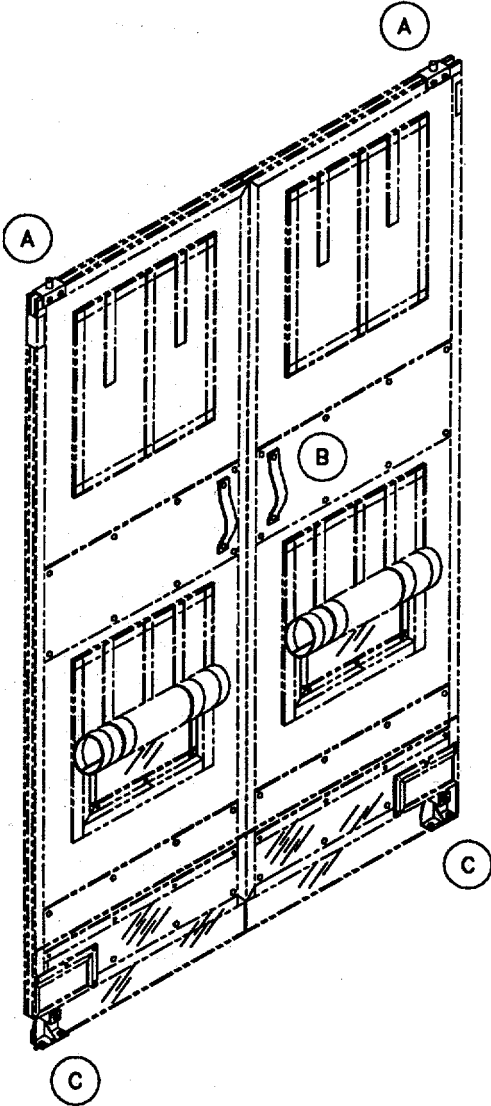

FIGURE 13. BUMP THROUGH DOORS (ISO TO ISO)

SECTION II

TM 10-5411-203-23P

(1) ITEM NO	(2) SMR CODE	(3) CAGEC	(4) PART NUMBER	(5) DESCRIPTION AND USABLE ON CODES (UOC)	(6) QTY
				<b>GROUP 02</b>	
				<b>COMPLEXING KIT PASSAGEWAYS</b>	
				<b>- TYPE I</b>	
				<b>FIG. 13</b>	
				<b>BUMP THROUGH DOORS</b>	
				<b>(ISO TO ISO)</b>	
1	XBOZZ	81337	5-4-4097-1	PIVOT,DOOR ASSY SAND..... UOC:FDM,FDP	2
1	XBOZZ	81337	5-4-4097-2	PIVOT,DOOR ASSY GREEN..... UOC:FDJ,FDN	2
2	XBOZZ	81337	5-4-7400	NYLON HANDLE..... UOC:FDJ,FDM,FDN,FDP	4
3	XBOZZ	81337	5-4-7401-1	PEDESTAL,DOOR ASSY SAND..... UOC:FDM,FDP	2
3	XBOZZ	81337	5-4-7401-2	PEDESTAL,DOOR ASSY GREEN..... UOC:FDJ,FDN	2
1	XDOZZ	81349	MIL-C-43285	CLOTH,COATED FACE COLOR SAND 33303..... PER FED-STD-595	V
2	XDOZZ	81349	MIL-C-43285	UOC:FDD,FOE,PDF,FDK,FDL,FDM,FDP CLOTH,COATED FACE COLOR GREEN..... 34094 PER FED-STD-595	V
3	XDOZZ	81349	MIL-C-43256	UOC:FDA,FDB,FDC,FDG,FDH,FDD,FDN CORD,POLYESTER 5/32 DIA COLOR ..... GREEN 34094 PER FED-STD-595	V
4	XDOZZ	81349	MIL-C-43256	UOC:FDA,FDB,FDC,FDG,FDH,FDJ,FDN CORD, POLYESTER 5/32 DIA COLOR SAND..... 33303 PER FED-STD-595	V
5	XDOZZ	96906	MS20001-14	HINGE.....	V
6	XDOZZ	81349	ZZ-R-765CL3B	SILICONE,RUBBER GRADE 50, COLOR..... BLACK	V
7	XDOZZ	81349	MIL-T-43566TYICL 4	TAPE,COTTON 1 IN. WIDE COLOR GREEN ..... 34094 PER FED-STD-595	V
8	XDOZZ	81349	MIL-T-43566TYICL 4	UOC:FDA,FDB,FDC,FDG,FDH,FDJ,FDN TAPE,COTTON 1 IN. WIDE COLOR SAND..... 33303 PER FED-STD-595	V
9	XDOZZ	81349	MIL-W-43668TYIII	UOC:FDD,FDE,PDF,FDK,FDL,FDM,FDP WEBBING,NYLON 1 IN. WIDE COLOR..... GREEN 33303 PER FED-STD-595	V
10	XDOZZ	81349	MIL-W-43668TYIII	UOC:FDA,FDB,FDC,FDG,FDN,FDJ,FDN WEBBING,NYLON 1 IN. WIDE COLOR..... SAND 33303 PER FED-STD-595	V
				UOC:FDD,FDE,PDF,FDK,FDL,FDM,FDP END OF FIGURE	

CROSS-REFERENCE INDEXES  
NATIONAL STOCK NUMBER INDEX

STOCK NUMBER

FIG.

ITEM

STOCK NUMBER

FIG.

ITEM

NO NSN INFORMATION AVAILABLE

## CROSS-REFERENCE INDEXES

CAGEC	PART NUMBER	PART NUMBER INDEX		FIG.	ITEM
			STOCK NUMBER		
08524	DCT7900-12-D-5			5	9
81349	MIL-C-43256			BULK	3
				BULK	4
81349	MIL-C-43285			BULK	1
				BULK	2
81349	MIL-G-16491TYIII CL3N02			7	15
81349	MIL-G-16491TYIII CL3N04			7	16
				12	6
81349	MIL-G-16491TYIII CL3ND6			12	10
81349	MIL-T-43566TYICL 4			BULK	7
				BULK	8
81349	MIL-W-43668TYIII			BULK	9
				BULK	10
96906	MS14237-507-P375			6	9
				11	9
96906	MS20001-14			BULK	5
96906	MS20426-AD4-7			3	2
96906	MS20613-6C24			5	2
96906	MS51844-82			4	3
				4	8
96906	MS51960-66			3	1
81349	M24243-6-A606F			5	6
				6	1
				6	17
				6	42
				11	1
				11	17
				11	42
81349	M24243/6-A606F/G G			2	7
81349	M24243-6-A606H			9	7
81349	M5501-7-F2			6	29
				11	29
02768	SLL			12	9
81348	UT-285TYICLISUBC LBSIZEF4			7	2
				7	4
				7	12
				12	2
81348	YT-285TYLCL1SUBC . LBSIZEF4			12	7
81348	VT-285TY0SUBCLB SIZEF4			7	17
81349	ZZ-R-765CL3B			BULK	6
81337	5-10-47FEMALE1IN			7	7
81337	5-10-47MALE1IN			7	9
81337	5-4-4029-1			2	10



## CROSS-REFERENCE INDEXES

CAGEC	PART NUMBER	PART NUMBER INDEX STOCK NUMBER	FIG.	ITEM
81337	5-4-4029-2		2	10
81337	5-4-4030-1		4	6
81337	5-4-4030-2		4	6
81337	5-4-4031-1		4	5
81337	5-4-4031-2		4	5
81337	5-4-4032-1		4	1
81337	5-4-4032-2		4	1
81337	5-4-4097-1		8	1
			13	1
81337	5-4-4097-2		8	1
			13	1
81337	5-4-4152-1		7	19
81337	5-4-4181-1		2	2
81337	5-4-4181-1-37		7	6
81349	5-4-4181-16		7	5
81337	5-4-4181-2		2	2
81337	5-4-4182-1		7	10
81337	5-4-4182-2		7	10
81337	5-4-4184-1		7	21
81337	5-4-4184-2		7	21
81337	5-4-4184-21		7	18
81337	5-4-4186-1		7	22
81337	5-4-4186-2		7	22
81337	5-4-4189-1		7	20
81337	5-4-4189-2		7	20
81337	5-4-4190-1		7	8
81337	5-4-4190-2		7	8
81337	5-4-4193-1		7	1
			12	1
81337	5-4-4193-2		7	1
			12	1
81349	5-4-4193-3		7	3
			12	3
81337	5-4-4196-1		2	8
81337	5-4-4196-2		2	8
81337	5-4-4197-1		5	1
81337	5-4-4197-2		5	1
81337	5-4-4200-1		5	5
81337	5-4-4200-2		5	5
81337	5-4-4201-1		5	4
81337	5-4-4202-1		9	2
81337	5-4-4202-8		12	5
81337	5-4-4202-2		9	2
81337	5-4-4203-1		12	4
81337	5-4-4203-1-16		12	8
81337	5-4-4203-2		12	4
81337	5-4-4203-2-16		12	8
81337	5-4-4204-1		2	3
			9	3
81337	5-4-4204-2		2	3
			9	3

## CROSS-REFERENCE INDEXES

CAGEC	PART NUMBER	PART NUMBER INDEX		FIG.	ITEM
			STOCK NUMBER		
81337	5-4-4205-1			6	8
				11	8
81337	5-4-4205-2			6	8
				11	8
81337	5-4-4213-1			2	5
				9	5
81337	5-4-4213-2			2	5
				9	5
81337	5-4-4227-1			4	2
				4	7
81337	5-4-4228-1			4	4
				4	4
81337	5-4-4228-2			4	4
				6	7
81337	5-4-4231-1			6	7
				6	27
81337	5-4-4234-1			11	7
				11	27
81337	5-4-4234-1			6	14
				6	23
81337	5-4-4234-1			6	34
				6	39
81337	5-4-4234-1			11	14
				11	23
81337	5-4-4234-1			11	34
				11	39
81337	5-4-4288-2			12	5
81337	5-4-5538-1			6	2
				11	2
81337	5-4-5538-2			6	3
				11	3
81337	5-4-5538-3			6	2
				11	2
81337	5-4-5538-4			6	3
				11	3
81337	5-4-5539-1			6	6
				6	13
81337	5-4-5539-1			6	22
				6	26
81337	5-4-5539-1			6	33
				6	38
81337	5-4-5539-1			11	6
				11	13
81337	5-4-5539-1			11	22
				11	26
81337	5-4-5539-1			11	33
				11	3B
81337	5-4-5540-1			5	3
				6	18
81337	5-4-5540-1			6	43
				11	18
81337	5-4-5540-1			11	43
				6	41

## CROSS-REFERENCE INDEXES

CAGEC	PART NUMBER	PART NUMBER INDEX		FIG.	ITEM
			STOCK NUMBER		
81337	5-4-5881-1			11	41
81337	5-4-5881-2			6	16
				11	16
81337	5-4-5882-1			6	5
				6	20
				6	25
				6	36
				11	5
				11	20
				11	25
				11	36
81337	5-4-5882-2			6	5
				6	11
				6	25
				6	31
				11	5
				11	11
				11	25
81337	5-4-5890-1			9	8
81337	5-4-5890-2			9	8
81337	5-4-5891-1			5	8
81337	5-4-5891-2			5	8
81337	5-4-6474-1			6	12
				6	21
				11	31
				11	31
81337	5-4-6474-2			6	37
				11	21
				11	37
81337	5-4-6475-1			3	6
				10	1
81337	5-4-6477-1			6	28
				11	28
81337	5-4-6477-2			6	28
				11	28
81337	5-4-6661-1			5	7
81337	5-4-6662-1			2	4
				9	4
81337	5-4-6662-2			2	4
				9	4
81337	5-4-6663-1			2	6
				9	6
81337	5-4-6663-2			2	6
				9	6
81337	5-4-6664-1			7	11
81337	5-4-6664-2			7	11
81337	5-4-6665-1			7	13
81349	5-4-6668-1-1			7	14
81337	5-4-6730-1			1	1
81337	5-4-6730-2			1	1

## CROSS-REFERENCE INDEXES

CAGEC	PART NUMBER	PART NUMBER INDEX		FIG.	ITEM
			STOCK NUMBER		
81337	5-4-6730-3			1	1
81337	5-4-6730-4			1	1
81337	5-4-6731-1			1	2
81337	5-4-6731-2			1	2
81337	5-4-6731-3			1	2
81337	5-4-6731-4			1	2
81337	5-4-6732-1			1	3
81337	5-4-6732-2			1	3
81337	5-4-6752-3			1	3
81337	5-4-6732-4			1	3
81337	5-4-6732-5			1	3
81337	5-4-6732-6			1	3
81337	5-4-6733-1			2	9
81337	5-4-6733-2			2	9
81337	5-4-6747-1			3	5
81337	5-4-6747-2			3	5
81337	5-4-6750-1			3	4
81337	5-4-6750-2			3	4
81337	5-4-6751-1			3	3
81337	5-4-7400			8	2
				13	2
81337	5-4-7401-1			8	3
				13	3
81337	5-4-7401-2			8	3
81337	5-4-7532-1			13	3
				9	9
				9	9
81337	5-4-7532-2			2	11
				9	9
				9	9
81337	5-4-8247-1			6	40
				11	40
81337	5-4-8247-2			6	40
				11	40
81337	5-4-8248-1			6	15
				11	15
81337	5-4-8248-2			6	15
				11	15
81337	5-4-8251-1			6	35
				11	35
81337	5-4-8251-2			6	35
				11	35
81337	5-4-8252-1			6	10
				11	10
81337	5-4-8252-2			6	10
				11	10
81337	5-4-8253-1			6	30
				11	30
81337	5-4-8253-2			6	30
				11	30

## CROSS-REFERENCE INDEXES

CAGEC	PART NUMBER	PART NUMBER INDEX		FIG.	ITEM
			STOCK NUMBER		
81337	5-4-8253-2			11	32
81337	5-4-8254-1			6	19
				11	19
81337	5-4-8254-2			6	19
				11	19
81337	5-4-8255-1			6	24
				11	24
81337	5-4-8255-2			6	24
81337	5-4-8256-1			6	4
				11	4
81337	5-4-8256-2			6	4
				11	4
81337	5-4-8258-1			2	1
81337	5-4-8258-2			2	1
81337	5-4-8259-1			9	1
81337	5-4-8259-2			9	1

## CROSS REFERENCE INDEXES

## FIGURE AND ITEM NUMBER INDEX

FIG.	ITEM	STOCK NUMBER	CAGEC	PART NUMBER
BULK	1		81349	MIL-C-43285
BULK	2		81349	MIL-C-43285
BULK	3		81349	MIL-C-43256
BULK	4		81349	MIL-C-43256
BULK	5		96906	MS20001-14
BULK	6		81349	ZZ-R-765CL38
BULK	7		81349	MIL-T-43566TYICL 4
BULK	8		81349	MIL-T-43566TYICL 4
BULK	9		81349	MIL-W-43668TYIII
BULK	10		81349	MIL-W-43668TYIII
1	1		81337	5-4-6730-1
1	1		81337	5-4-6730-2
1	1		81337	5-4-6730-3
1	1		81337	5-4-6730-4
1	2		81337	5-4-6731-1
1	2		81337	5-4-6731-2
1	2		81337	5-4-6731-3
1	2		81337	5-4-6731-4
1	3		81337	5-4-6732-1
1	3		81337	5-4-6732-2
1	3		81337	5-4-6732-3
1	3		81337	5-4-6732-4
1	3		81337	5-4-6732-5
1	3		81337	5-4-6732-6
2	1		81337	5-4-8258-1
2	1		81337	5-4-8258-2
2	2		81337	5-4-4181-1
2	2		81337	5-4-4181-2
2	3		81337	5-4-4204-1
2	3		81337	5-4-4204-2
2	4		81337	5-4-6662-1
2	4		81337	5-4-6662-2
2	5		81337	5-4-4213-1
2	5		81337	5-4-4213-2
2	6		81337	5-4-6663-1
2	6		81337	5-4-6663-2
2	7		81349	M24243/6-A606F/G G
2	8		81337	5-4-4196-1
2	8		81337	5-4-4196-2
2	9		81337	5-4-6733-1
2	9		81337	5-4-6733-2
2	10		81337	5-4-4029-1
	10		81337	5-4-4029-2
2	11		81337	5-4-7532-1
2	11		81337	5-4-7532-2
3	1		96906	MS51960-66
3	2		96906	MS20426-AD4-7
3	3		81337	5-4-6751-1

## CROSS REFERENCE INDEXES

FIG.	ITEM	FIGURE AND ITEM NUMBER INDEX		PART NUMBER
		STOCK NUMBER	CAGEC	
3	4		81337	5-4-6750-1
3	4		81337	5-4-6750-2
3	5		81337	5-4-6747-1
3	5		81337	5-4-6747-2
3	6		81337	5-4-6475-1
4	1		81337	5-4-4032-1
4	1		81337	5-4-4032-2
4	2		81337	5-4-4227-1
4	3		96906	MS51844-82
4	4		81337	5-4-4228-1
4	4		81337	5-4-4228-2
4	5		81337	5-4-4031-1
4	5		81337	5-4-4031-2
4	6		81337	5-4-4030-1
4	6		81337	5-4-4030-2
4	7		81337	5-4-4227-1
4	8		96906	MS51844-82
5	1		81337	5-4-4197-1
5	1		81337	5-4-4197-2
5	2		96906	MS20613-6C24
5	3		81337	5-4-5540-1
5	4		81337	5-4-4201-1
5	5		81337	5-4-4200-1
5	5		81337	5-4-4200-2
5	6		81349	M24243-6-A606F
5	7		81337	5-4-6661-1
5	8		81337	5-4-5891-1
5	8		81337	5-4-5891-2
5	9		08524	DCT7900-12-D-5
6	1		81349	M24243-6-A606F
6	2		81337	5-4-5538-1
6	2		81337	5-4-5538-3
6	3		81337	5-4-5538-2
6	3		81337	5-4-5538-4
6	4		81337	5-4-8256-1
6	4		81337	5-4-8256-2
6	5		81337	5-4-5882-1
6	5		81337	5-4-5882-2
6	6		81337	5-4-5539-1
6	7		81337	5-4-4231-1
6	8		81337	5-4-4205-1
6	8		81337	5-4-4205-2
6	9		96906	MS14237-507-P375
6	10		81337	5-4-8252-1
6	10		81337	5-4-8252-2
6	11		81337	5-4-5882-2
6	12		81337	5-4-6474-1
6	13		81337	5-4-5539-1
6	14		81337	5-4-4234-1
6	15		81337	5-4-8248-1
6	15		81337	5-4-8248-2

## CROSS REFERENCE INDEXES

## FIGURE AND ITEM NUMBER INDEX

FIG.	ITEM	STOCK NUMBER	CAGEC	PART NUMBER
6	16		81337	5-4-5881-2
6	17		81349	M24243-6-A606F
6	18		81337	5-4-5540-1
6	19		81337	5-4-8254-1
6	19		81337	5-4-B254-2
6	20		81337	5-4-5882-1
6	21		81337	5-4-6474-1
6	22		81337	5-4-5539-1
6	23		81337	5-4-4234-1
6	24		81337	5-4-8255-1
6	24		81337	5-4-8255-2
6	25		81337	5-4-5882-1
6	25		81337	5-4-5882-2
6	26		81337	5-4-5539-1
6	27		81337	5-4-4231-1
6	28		81337	5-4-6477-1
6	28		81337	5-4-6477-2
6	29		81349	M5501-7-F2
6	30		81337	5-4-8253-1
6	30		81337	5-4-8253-2
6	31		81337	5-4-5882-2
6	32		81337	5-4-6474-1
6	33		81337	5-4-5539-1
6	34		81337	5-4-4?34-1
6	35		81337	5-4-8251-1
6	35		81337	5-4-8251-2
6	36		81337	5-4-5882-1
6	37		81337	5-4-6474-2
6	38		81337	5-4-5539-1
6	39		81337	5-4-4234-1
6	40		81337	5-4-8247-1
6	40		81337	5-4-8247-2
6	41		81337	5-4-5881-1
6	42		81349	M24243-6-A606F
6	43		81337	5-4-5540-1
7	1		81337	5-4-4193-1
7	1		81337	5-4-4193-2
7	2		81348	VT-285TYICLISUBC LBSIZEF4
7	3		81349	5-4-4193-3
7	4		81348	VT-285TYICLISUBC LBSIZ6F4
7	5		81349	5-4-4181-16
7	6		81337	5-4-4181-1-37
7	7		81337	5-10-47FEMALE1IN
7	8		81337	5-4-4190-1
7	8		81337	5-4-4190-2
7	9		81337	5-10-47MALE1IN
7	10		81337	5-4-4182-1
7	10		81337	5-4-4182-2
7	11		81337	5-4-6664-1



## CROSS REFERENCE INDEXES

FIG.	ITEM	FIGURE AND ITEM NUMBER INDEX		PART NUMBER
		STOCK NUMBER	CAGEC	
7	11		81337	5-4-6664-2
7	12		81348	VT-285TYICL1SUBC LBSIZEF4
7	13		81337	5-4-6665-1
7	14		81349	5-4-6668-1-1
7	15		81349	MIL-G-16491TYIII CL3N02
7	16		81349	MIL-G-16491TYIII CL3N04
7	17		81348	VT-285TY1SUBCLB SIZEF4
7	18		81337	5-4-4184-21
7	19		81337	5-4-4152-1
7	20		81337	5-4-4189-1
7	20		81337	5-4-4189-2
7	21		81337	5-4-4184-1
7	21		81337	5-4-4184-2
7	22		81337	5-4-4186-1
7	22		81337	5-4-4186-2
8	1		81337	5-4-4097-1
8	1		81337	5-4-4097-2
8	2		81337	5-4-7400
8	3		81337	5-4-7401-1
8	3		81337	5-4-7401-2
9	1		81337	5-4-8259-1
9	1		81337	5-4-8259-2
9	2		81337	5-4-4202-1
9	2		81337	5-4-4202-2
9	3		81337	5-4-4204-1
9	3		81337	5-4-4204-2
9	4		81337	5-4-6662-1
9	4		81337	5-4-6662-2
9	5		81337	5-4-4213-1
9	5		81337	5-4-4213-2
9	6		81337	5-4-6663-1
9	6		81337	5-4-6663-2
9	7		81349	M24243/6-A606H
9	8		81337	5-4-5890-1
9	8		81337	5-4-5890-2
9	9		81337	5-4-7532-1
9	9		81337	5-4-7532-1
9	9		81337	5-4-7532-2
9	9		81337	5-4-7532-2
10	1		81337	5-4-6475-1
11	1		81349	M24243/6-A606F
11	2		81337	5-4-5538-1
11	2		81337	5-4-5538-3
11	3		81337	5-4-5538-2
11	3		81337	5-4-5538-4
11	4		81337	5-4-8256-1
11	4		81337	5-4-8256-2

## CROSS REFERENCE INDEXES

FIGURE AND ITEM NUMBER INDEX				
FIG.	ITEM	STOCK NUMBER	CAGEC	PART NUMBER
11	5		81337	5-4-5882-1
11	5		81337	5-4-5882-2
11	6		81337	5-4-5539-1
11	7		81337	5-4-4231-1
11	8		81337	5-4-4205-1
11	8		81337	5-4-4205-2
11	9		96906	MS14237-507-P375
11	10		81337	5-4-8252-1
11	10		81337	5-4-8252-2
11	11		81337	5-4-5882-2
11	12		81337	5-4-6474-1
11	13		81337	5-4-5539-1
11	14		81337	5-4-4234-1
11	15		81337	5-4-8248-1
11	15		81337	5-4-8248-2
11	16		81337	5-4-5881-2
11	17		81349	M24243/6-A606F
11	18		81337	5-4-5540-1
11	19		81337	5-4-8254-1
11	19		81337	5-4-8254-2
11	20		81337	5-4-5882-1
11	21		81337	5-4-6474-2
11	22		81337	5-4-5539-1
11	23		81337	5-4-4234-1
11	24		81337	5-4-8255-1
11	24		81337	5-4-8255-2
11	25		81337	5-4-5882-1
11	25		81337	5-4-5882-2
11	26		81337	5-4-5539-1
11	27		81337	5-4-4231-1
11	28		81337	5-4-6477-1
11	28		81337	5-4-6477-2
11	29		81349	M5501-7-F2
11	30		81337	5-4-8253-1
11	30		81337	5-4-8253-2
11	31		81337	5-4-6474-1
11	32		81337	5-4-8253-2
11	33		81337	5-4-5539-1
11	34		81337	5-4-4234-1
11	35		81337	5-4-8251-1
11	35		81337	5-4-8251-2
11	36		81337	5-4-5882-1
11	37		81337	5-4-6474-2
11	38		81337	5-4-5539-1
11	39		81337	5-4-4234-1
11	40		81337	5-4-8247-1
11	40		81337	5-4-8247-2
11	41		81337	5-4-5881-1
11	42		81349	M24243-6-A606F
11	43		81337	5-4-5540-1
12	1		81337	5-4-4193-1

## CROSS REFERENCE INDEXES

FIG.	ITEM	FIGURE AND ITEM NUMBER INDEX		PART NUMBER
		STOCK NUMBER	CAGEC	
12	1		81337	5-4-4193-2
12	2		81348	VT-285TYICLISUBC LBSIZEF4
12	3		81349	5-4-4193-3
12	4		81337	5-4-4203-1
12	4		81337	5-4-4203-2
12	5		81337	5-4-4202-1-8
12	5		81337	5-4-4288-2
12	6		81349	MIL-G-16491TYIII CL3N04
12	7		81348	VT-285TYLCLISUBC LBSIZEF4
12	8		81337	5-4-4203-1-16
12	8		81337	5-4-4203-2-16
12	9		02768	SLL
12	10		81349	MIL-G-16491TYIII CL3N06
13	1		81337	5-4-4097-1
13	1		81337	5-4-4097-2
13	2		81337	5-4-7400
13	3		81337	5-4-7401-1
13	3		81337	5-4-7401-2

By Order of the Secretary of the Army:

Official:

GORDON R. SULLIVAN  
*General, United States Army*  
*Chief of Staff*

MILTON H. HAMILTON  
*Administrative Assistant to the*  
*Secretary of the Army*

DISTRIBUTION:

To be distributed in accordance with DA Form 12-25-E, block no. 5262, requirements for TM 10-5411-203-23P.

RECOMMENDED CHANGES TO EQUIPMENT TECHNICAL PUBLICATIONS



THEN...JOT DOWN THE DOPE ABOUT IT ON THIS FORM. CAREFULLY TEAR IT OUT, FOLD IT AND DROP IT IN THE MAIL.

**SOMETHING WRONG WITH PUBLICATION**

FROM: (PRINT YOUR UNIT'S COMPLETE ADDRESS)

DATE SENT

PUBLICATION NUMBER	PUBLICATION DATE	PUBLICATION TITLE
--------------------	------------------	-------------------

BE EXACT PIN-POINT WHERE IT IS				IN THIS SPACE, TELL WHAT IS WRONG AND WHAT SHOULD BE DONE ABOUT IT.
PAGE NO.	PARA-GRAPH	FIGURE NO.	TABLE NO.	

TEAR ALONG PERFORATED LINE

PRINTED NAME, GRADE OR TITLE AND TELEPHONE NUMBER	SIGN HERE
---	-----------

DA FORM 1 JUL 79 2028-2

PREVIOUS EDITIONS ARE OBSOLETE.

P.S.--IF YOUR OUTFIT WANTS TO KNOW ABOUT YOUR RECOMMENDATION MAKE A CARBON COPY OF THIS AND GIVE IT TO YOUR HEADQUARTERS.

# The Metric System and Equivalents

## Linear Measure

1 centimeter = 10 millimeters = .39 inch  
 1 decimeter = 10 centimeters = 3.94 inches  
 1 meter = 10 decimeters = 39.37 inches  
 1 dekameter = 10 meters = 32.8 feet  
 1 hectometer = 10 dekameters = 328.08 feet  
 1 kilometer = 10 hectometers = 3,280.8 feet

## Weights

1 centigram = 10 milligrams = .15 grain  
 1 decigram = 10 centigrams = 1.54 grains  
 1 gram = 10 decigrams = .035 ounce  
 1 dekagram = 10 grams = .35 ounce  
 1 hectogram = 10 dekagrams = 3.52 ounces  
 1 kilogram = 10 hectograms = 2.2 pounds  
 1 quintal = 100 kilograms = 220.46 pounds  
 1 metric ton = 10 quintals = 1.1 short tons

## Liquid Measure

1 centiliter = 10 milliliters = .34 fl. ounce  
 1 deciliter = 10 centiliters = 3.38 fl. ounces  
 1 liter = 10 deciliters = 33.81 fl. ounces  
 1 dekaliter = 10 liters = 2.64 gallons  
 1 hectoliter = 10 dekaliters = 26.42 gallons  
 1 kiloliter = 10 hectoliters = 264.18 gallons

## Square Measure

1 sq. centimeter = 100 sq. millimeters = .155 sq. inch  
 1 sq. decimeter = 100 sq. centimeters = 15.5 sq. inches  
 1 sq. meter (centare) = 100 sq. decimeters = 10.76 sq. feet  
 1 sq. dekameter (are) = 100 sq. meters = 1,076.4 sq. feet  
 1 sq. hectometer (hectare) = 100 sq. dekameters = 2.47 acres  
 1 sq. kilometer = 100 sq. hectometers = .386 sq. mile

## Cubic Measure

1 cu. centimeter = 1000 cu. millimeters = .06 cu. inch  
 1 cu. decimeter = 1000 cu. centimeters = 61.02 cu. inches  
 1 cu. meter = 1000 cu. decimeters = 35.31 cu. feet

## Approximate Conversion Factors

To change	To	Multiply by	To change	To	Multiply by
inches	centimeters	2.540	ounce-inches	newton-meters	.007062
feet	meters	.305	centimeters	inches	.394
yards	meters	.914	meters	feet	3.280
miles	kilometers	1.609	meters	yards	1.094
square inches	square centimeters	6.451	kilometers	miles	.621
square feet	square meters	.093	square centimeters	square inches	.155
square yards	square meters	.836	square meters	square feet	10.764
square miles	square kilometers	2.590	square meters	square yards	1.196
acres	square hectometers	.405	square kilometers	square miles	.386
cubic feet	cubic meters	.028	square hectometers	acres	2.471
cubic yards	cubic meters	.765	square meters	cubic feet	35.315
fluid ounces	milliliters	29.573	cubic meters	cubic yards	1.308
pints	liters	.473	milliliters	fluid ounces	.034
quarts	liters	.946	liters	pints	2.113
gallons	liters	3.785	liters	quarts	1.057
ounces	grams	28.349	liters	gallons	.264
pounds	kilograms	.454	grams	ounces	.035
short tons	metric tons	.907	kilograms	pounds	2.205
pound-foot	newton-meters	1.356	metric tons	short tons	1.102
pound-inches	newton-meters	.11296			

## Temperature (Exact)

°F	Fahrenheit temperature	5/9 (after subtracting 32)	Celsius temperature	°C
----	------------------------	----------------------------	---------------------	----

**PIN: 067796-000**